

# SHADE TREE A'S

## NEWSLETTER

June 2019

Volume 46

Number 6



<b>President</b> Matt Barrett	706-799-3699 pres@ShadeTreeAs.org
<b>Vice President</b> Darrell Henderson	706-863-1673 vp@ShadeTreeAs.org
<b>Secretary</b> Frank Knapp	706-736-5238 sec@ShadeTreeAs.org
<b>Treasurer</b> Richard Dunevent	706-339-8167 treas@ShadeTreeAs.org
<b>Tour Director</b> OPEN	tourdir@ShadeTreeAs.org
<b>National Director</b> Jim McPherson	706-592-4835 nationaldir@ShadeTreeAs.org
<b>Board of Directors</b> Dan Perla	706-855-5730 bod1@ShadeTreeAs.org
<b>Board of Directors</b> Stuart Smith	706-825-9441 bod2@ShadeTreeAs.org
<b>Membership Coordinator</b> OPEN	membership@ShadeTreeAs.org
<b>Newsletter Editor</b> Robbie Jones	706-860-2758 newsletter@ShadeTreeAs.org
<b>Photographer</b> Sheila McPherson	706-592-4835 photographer@ShadeTreeAs.org
<b>Era Fashions</b> Anne Neely-Beck	478-945-3736 erafashions@ShadeTreeAs.org
<b>Webmaster</b> Dan Perla	706-855-5730 webmaster@ShadeTreeAs.org

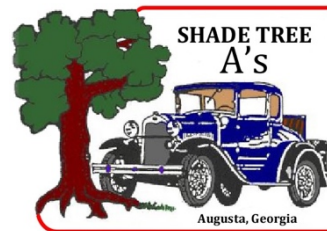

## CONTENTS

### Columns

Off the Running Board	3
Meeting Minutes	3
<b>Looking Ahead</b>	
Club Calendar	5
Refreshments	5
Birthdays	5
<b>Announcements</b>	
Shade Tree A's Member News	6
Other Sundry Announcements	6
<b>Recent Events</b>	
Remembering Penny Pinson	9
Jim Dover's 95 <sup>th</sup> Birthday Party	10
The Shade Tree A's - Thirty Years Ago	11
<b>Technical Topics</b>	
And the Model A Ford Kept Rambling Right Along	12
Attaching Stone Guard	14
<b>Advertisements</b>	15

### On the Cover

Model A's from the Shade Tree A's and other clubs from the surrounding region (well, technically their owners) tour to Magnolia Springs State Park on June 1, 2019. Photo by Matt Barrett.

## SHADE TREE A'S MODEL A CLUB



The Shade Tree A's Model A Club is a non-profit organization dedicated to the preservation and the restoration of the Model A Ford automobile. Shade Tree A's annual dues are only \$25. Members are urged to join the Model A Ford Club of America (MAFCA, \$50 annual dues) and the Model A Restorer's Club (MARC, \$45 annual dues) to enjoy the benefits of these national organizations including their respective magazines: *The Restorer* (MAFCA) and *Model A News* (MARC). The Shade Tree A's club is also a member of MAFFI, the Model "A" Ford Foundation, Inc.

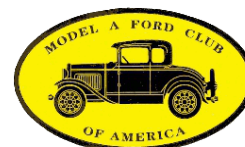

**CONTACT INFORMATION**  
 4424 Reynolds Street  
 Hephzibah GA 30815-7909  
 Website: <http://www.ShadeTreeAs.org>  
 Facebook: Shade Tree A's Model A Ford Club

**ABOUT THIS NEWSLETTER**  
 © 2019 Shade Tree A's, except as noted.  
 Please contact Robbie Jones at [Newsletter@ShadeTreeAs.org](mailto:Newsletter@ShadeTreeAs.org) concerning reprinting of articles, illustrations, or photos.

## OFF THE RUNNING BOARD

*Matt Barrett - President*

Greetings fellow club members 🤪

Our joint tour to Magnolia Springs State Park in Millen, Ga was just fabulous!!! If you weren't there, we missed you and you missed out on the best tour of the year so far. There were almost 40 folks that came from three Model A Clubs: the Live Oaks Club, the STA Club and the Palmetto Model A Club. Everyone there agreed that this needs to be a yearly tour.

Don't forget that we will be at Sconyer's in August with family members. We will not need a head count but bring as many family members as you like. We will be in the large upstairs dining room on Thursday, August 15<sup>th</sup> at 6:00 pm. Be sure you make plans to attend.

The outside temperature has gotten hot very fast so our cars 🚗 need to be driven early in the morning or late in the evening. Our "four windows down traveling 40 miles per hour" air conditioning helps a little bit but the midday temperatures are brutal 🔥🤔🔥

Our next meeting will be held June 10<sup>th</sup> at Richard's Garage, so be sure to attend and if possible drive your A Model.

Hope to see you soon.

Your president,  
Matt Barrett

## MEETING MINUTES

*May 13, 2019*

*Richard's Garage*

*Recorded by: Frank Knapp – Secretary*

The monthly meeting of the Shade Tree A's was held May 13, 2019 in the clubhouse meeting room at Richard Dunevent's garage. President Matt gaveled the meeting to order promptly at 7:00 P.M. Twenty-two members were in attendance.

Once again, President Matt entertained the group with our "joke of the month". Apparently one he had not committed to memory since he required the assistance of his iPad to properly relate what resulted in a "good one"!

Thanks for the humor, Matt!

Treasurer's Report:

Dan Perla reported only our Annual Corporate Fees were paid in the last month leaving our accounts relatively stable. Thanks, Dan, for your continued supervision of our finances.

A motion was made from the floor to accept the April Minutes and the May Treasurer's Report. That motion received a second and passed by unanimous vote.

National Director:

Jim McPherson reported several clubs will be attending our IMAFD activities this fall. Those mentioned included Jacksonville, Savannah, Old 96, Charleston and Aiken.

*Continued on next page*

## MEETING MINUTES

*(continued)*

### Newsletter Editor:

Robbie Jones related having received several email "bounce backs" when *The Newsletter* is sent electronically to the membership each month. In order to update his group email list, he asked anyone not receiving our newsletter to check with him if their email address has changed.

### Under Show & Tell.

Robbie Jones passed around what appeared to be some type of wheel puller. The interesting question being its actual use since it did not resemble any used on the Model A. No definite answer was forthcoming!

### Under Old Business:

President Matt announced he is expecting a large turnout for the STA's multi-club picnic to be held June 1<sup>st</sup> at Magnolia Springs State Park in Millen, Georgia. Plans are to depart from Matt's home (611 Scott's Way) at 9 AM. The STAs will provide chicken fingers, paper plates, etc. Members planning to attend were urged to bring their favorite side dish.

No New Business was brought to the floor.

### Technical Program:

Vice President Darrell provided a very interesting movie concerning Ford's Model A assembly plant located in Yokohama, Japan. All found the information provided by the documentary both entertaining and informative!

There being no further business, the meeting was adjourned at 8:05 PM after which, Ice Cream, Cake and Cookies, were provided by Stuart Smith, Craig McMullin and Curtis Krosting.

Respectfully Submitted: Frank Knapp, Secretary

### MONTHLY MEETING TIME & LOCATION

Meetings are held on the 2nd Monday of each month at Richard Dunevent's garage, 4338 Owens Road, Evans, GA. Meetings begin at 7PM and are followed by refreshments.

# LOOKING AHEAD

## Club Calendar

### June

- 1 Shade Tree A's tour to Magnolia Springs State Park
- 10 Shade Tree A's Meeting, 7:00 PM, Richard's garage  
(Technical Program TBA)
- 15 Trenton Ridge Peach Festival and Parade
- 21-22 Palmetto A's Swap Meet and People's Choice Car Show

### July

- 8 Shade Tree A's Meeting, 7:00 PM, Richard's garage  
(Technical Program TBA)

### August

- 15 Shade Tree A's Summer Dinner Meeting, 6:00 PM, Sconyer's Bar-B-Que (meet in the large dining room upstairs)

TBA - To Be Announced

## June Refreshments



Darrell Henderson  
Richard Dunevent  
Gerald Melchiors



## June Birthdays

- 6 Matt Barrett
- 7 Chuck Howell
- 22 Chan Drake
- 30 Phyllis Drake

## ANNOUNCEMENTS

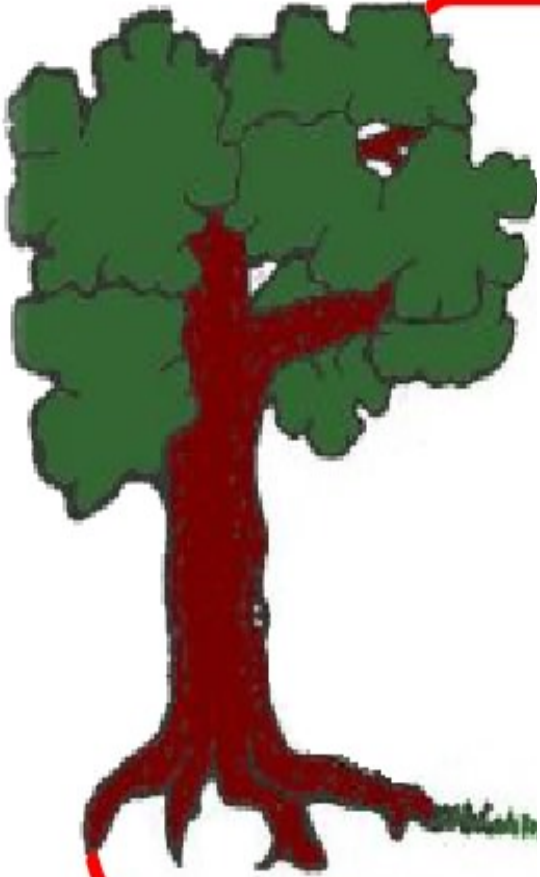

### Shade Tree A's Member News

- Tina Neitzke, beloved wife of 47 years of Ralph Neitzke, passed away May 25, 2019. Please remember Ralph in your thoughts and prayers.

*Send items for Shade Tree A's Member News to:  
newsletter@ShadeTreeAs.org*

### Monthly Technical Program

Got an idea for a technical program for presentation at a monthly meeting?

Got a topic you would like discussed during a monthly technical program?

Do you want to volunteer to present a technical program?

If so, contact Darrell Henderson at [vp@ShadeTreeAs.org](mailto:vp@ShadeTreeAs.org) or 706-863-1673

ANNOUNCEMENTS

NEW DATE!!  
21-22 JUNE, 2019

NEW DATE!!  
21-22 JUNE, 2019

14th Annual  
ALL Model A & Model T  
SWAP MEET & PEOPLE'S CHOICE CAR SHOW  
at

Smith & Jones Antique Auto Parts  
60 Wisconsin St. West Columbia, SC

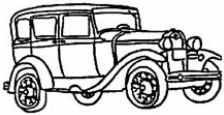

sponsored by

*Palmetto A's of South Carolina*

Friday, June 21, 2019 8am to 5pm Swap Meet  
Saturday, June 22, 2019 8am to 3pm Swap Meet & Car Show  
Vendor Space: Early registration: \$15/one day \$25/two days \$20/\$30 at the gate  
Car Corral: \$10 for two days  
Palmetto A Members - Free Vendor Space  
\$2 Door Prize Tickets Food Concession 50/50  
Contact: Dick Fraser  
dickfraser@earthlink.net 803-622-7582

Vendor Sign Up Form

Name: \_\_\_\_\_  
Address \_\_\_\_\_  
City \_\_\_\_\_ State \_\_\_\_\_ Zip \_\_\_\_\_  
Telephone \_\_\_\_\_ email \_\_\_\_\_

Will you be arriving and setting up on Thursday, June 20? \_\_\_\_\_  
Are you primarily a Model A or Model T vendor? \_\_\_\_\_

Please mail this form along with a check or money order made payable to:  
Palmetto A's of SC--- 113 Ian Dr. Leesville, SC 29070

By participation in this event and signing this form I/we agree to hold harmless  
The Palmetto A's of SC Model A Club, Smith & Jones Antique Auto Parts and any of the  
members or agents thereof, in the event of accident or injury to any participant, person or group.

Signature \_\_\_\_\_ Date \_\_\_\_\_

ANNOUNCEMENTS

**9th Annual Model A Day**

**Swap Meet**  
**Fashion, Seminars,**  
**Food and Fun!**

**September 21st 2019 9-5pm**

**The Gilmore Car Museum**  
**6865 W. Hickory Road**  
**Hickory Corners, MI 49060**

**Special Parking**  
**For all Un-restored**  
**Model A's**

**Technical Seminars, Fashion, Hall of Fame Induction**

**GENUINE FORD PARTS**    **AUTHORIZED FORD DEALER**    **FORD AUTHORIZED SERVICE**

**Hotel Info: Four Points Sheraton, 3600 E. Cork St.**  
**Kalamazoo, MI 49001 269.385.3922**



**For more Info 810-798- 8803 Lou Ironside**

**For Swap Reservations and information**  
**Ken Ehrenhofer 630-697-3906 or Mark Maron 847-302-7900**





## RECENT EVENTS

### Remembering Penny Pinson

*Story by Jim McPherson  
Photos by Sheila McPherson*

Jim and Sheila McPherson traveled to Greenwood, SC on Saturday May 11<sup>th</sup> for Penny Pinson Hot Dog Day. The event was hosted by the Old 96 District A's at Emerald Farm in memory of Penny Pinson. Penny loved Model A's and started Hot Dog Day to bring together fellow Model A'ers for a day of fellowship. At lunch time, Penny would go to the local convenience store and purchase hot dogs for everyone. Penny frequently toured with the Shade Tree A's throughout the southeast. It is in his memory the Old 96 District A's hold Penny Pinson Hot Dog Day each year.



RECENT EVENTS

Jim Dover's 95<sup>th</sup> Birthday Party

*Photos by Sheila McPherson*

Shade Tree A's member Jim Dover celebrated his 95<sup>th</sup> birthday on May 4, 2019 at Josh and Becky Dover's home, complete with a Model A birthday cake. Happy Birthday Jim!



# THE SHADE TREE A'S – THIRTY YEARS AGO



The 1985-2005 Shade Tree A's newsletters are now available on the Shade Tree A's website. They can be accessed via the same "button" as the other newsletters, but they are password protected. The same password used to access the member roster is used to access the newsletters. Thank you Dan Perla for scanning these and posting on the website.

The June 1989 issue of the Shade Tree A's Newsletter revealed the reason for the engine modifications shown in the May 1989 Newsletter. An article on "The Great Hot Rod Race" was also included. A crash course on shopping for Model A parts at flea markets was promised for the upcoming June Club meeting. Sounds like an interesting discussion that could be repeated before Hershey 2019!

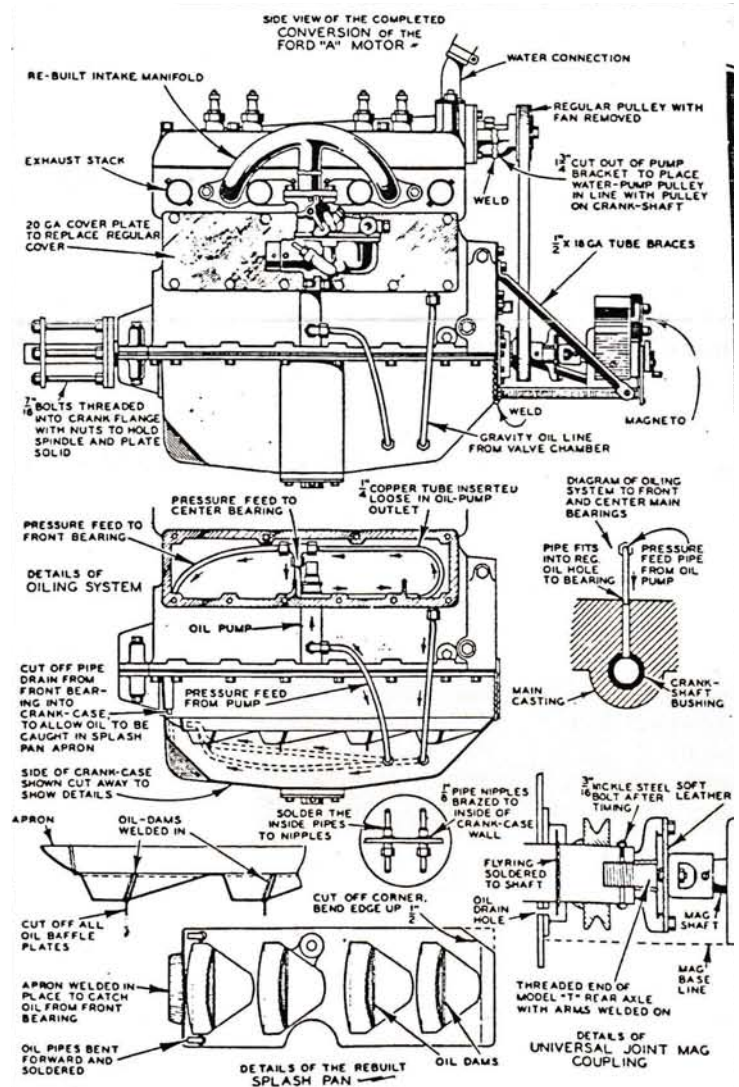
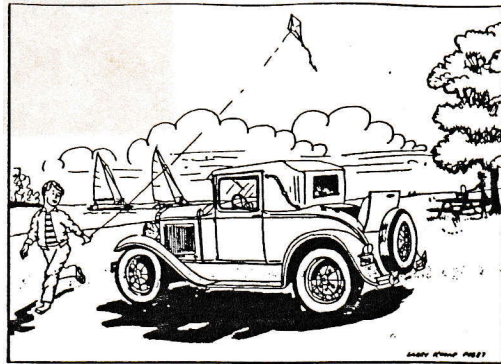

## TECHNICAL TOPICS

### And the Model A Ford Kept Rambling Right Along

By Jim McPherson

*This column contains maintenance, diagnostic, and technical tips to aid you in keeping your Model A on the road and operating at peak performance. I have stolen this information from a variety of sources, including forums, websites, books, publications, and discussions with fellow Model A owners.*

The spark plug gap for the standard Model A head (A6050A) should be 0.035", the spark plug gap for the 1930-31 Model A "police" head (A6050B) should be 0.025", and the spark plug gap for the Model B head (B6050B) should be 0.030". The spark plugs should be torqued to 25 ft. lbs.

For the best spark plug for your Model A, the goal is to choose a spark plug which prevents fouling. You would like your spark plugs to "read" the same, that is to have a tan, brown or light gray color to the part of the spark plug which is exposed in the combustion chamber. To determine which spark plug is best for your engine, drive your Model A for several miles at 40-45 mph, then immediately push in the clutch, turn off the ignition switch and coast off the road. Then remove each spark plug and "read" the spark plug. If it is not tan, brown or gray, you may want to try a hotter or cooler spark plug to obtain one of these colors. It is important for you to push in the clutch and cut off the ignition as soon as possible to avoid an incorrect reading. If not, this could cause a rich or lean mixture and give you a false spark plug reading.

These are spark plugs commonly used in the Model A. There are many others, including era spark plugs which are available at swap meets at a very reasonable price. These spark plugs are listed from hot to cold:

Champion:

W95D  
W89D  
W16Y  
W16C  
W18  
W14  
W10  
W85N  
W80N

Motorcraft:

TT15  
TT10  
TT8  
TT4

Autolite:

3076

Mopar:

P-9-7S  
P-9-6S  
P-9-5S

TECHNICAL TOPICS

And the Model A Ford Kept Rambling Right Along

(continued)

The spark plug number is the heat range. As a general rule, the lower the number, the cooler the spark plug. The heat range refers to the ability of the spark plug design to conduct heat away from the spark plug, especially the portion of the spark plug exposed in the combustion chamber. It does not refer to the heat of the spark, which is controlled by the coil and is always the same, regardless of which spark plug you are using. If your engine is burning oil or your carburetor mixture is rich, you want to run a hotter spark plug to keep the spark plug electrode clean longer. If you run too hot of a spark plug, you will promote engine knock, which may result in other bad engine problems.



**Normal condition** – A brown, tan or grey firing end indicates that the engine is in good condition and that the plug type is correct.



**Ash deposits** – Light brown deposits encrusted on the electrodes and insulator, leading to misfire and hesitation. Caused by excessive amounts of oil in the combustion chamber or poor quality fuel/oil.



**Carbon fouling** – Dry, black sooty deposits leading to misfire and weak spark. Caused by an over-rich fuel/air mixture, faulty choke operation or blocked air filter.



**Oil fouling** – Wet oily deposits leading to misfire and weak spark. Caused by oil leakage past piston rings or valve guides (4-stroke engine), or excess lubricant (2-stroke engine).



**Overheating** – A blistered white insulator and glazed electrodes. Caused by ignition system fault, incorrect fuel, or cooling system fault.



**Worn plug** – Worn electrodes will cause poor starting in damp or cold conditions and will also waste fuel.

## TECHNICAL TOPICS

### Attaching Stone Guard Badge

*Story and photos by Matt Barrett*

I purchased a MARC badge in Richmond Hill, Ga and wanted to attach it to my radiator stone guard. I wanted something that would last and also would not rust. So I found in my workshop some plastic electrical wire staples. I removed the nails and used a number 6 x 1/2" stainless steel screw and was able to use this setup to attach my badge. These staples fit in between the stone guard mesh and can be secured or removed at your discretion.

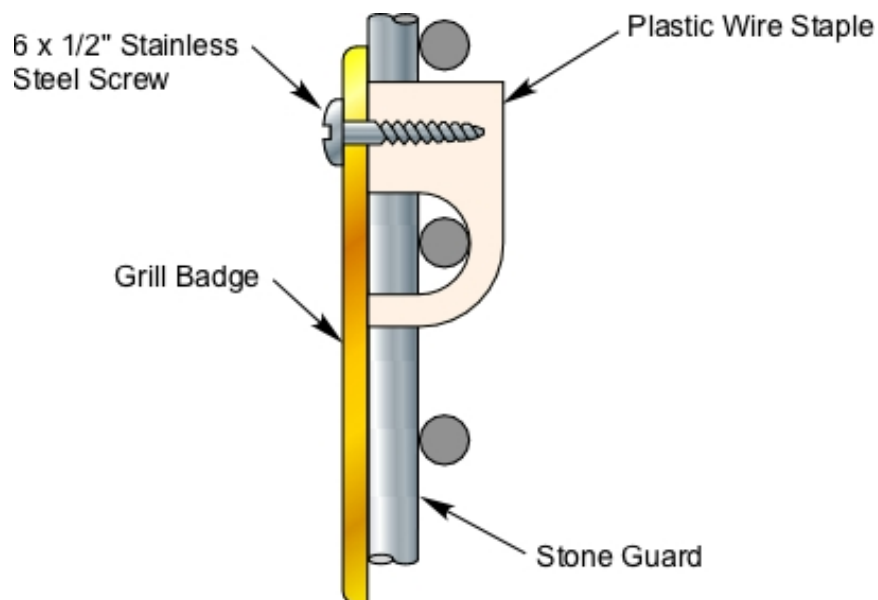

### Member Advertisements

Deadline for submittal – 20<sup>th</sup> of the month – Send submittals to [newsletter@ShadeTreeAs.org](mailto:newsletter@ShadeTreeAs.org)

- Float-A-Motor rear mounts. Used, but in good usable condition. \$40
- Valve cover that is set up for the full flow oil filter. Includes the internal connecting tube. All you will need is a new gasket and the filter. \$75
- Original Model A Instruction Books (Owner’s Manual). Prices based on condition, \$25 to \$195.

Don Turley, Call 706-863-4867, leave a message and I will return your call. Or email [don@donturley.com](mailto:don@donturley.com)

### Paid Advertisements



**E Walker Crosby**  
Agency Owner



**Allstate Insurance Company**  
1890 Huntsman Drive  
Aiken, SC 29803

Phone 803-642-6560  
Fax 803-642-6561  
walkercrosby@allstate.com  
allstateagencies.com/walkercrosby

Personalized Service.  
Trusted advice.

M-F 8:30 to 5:30 Weekends by appt.  
Auto, Home, Life, Retirement

1003 ALEXANDER DRIVE  
AUGUSTA, GA 30909

P.O. BOX 212072  
MARTINEZ, GA 30917



**D'Antignac & Merritt Heating & Air, Inc.**  
Turn To The Experts.

(706) 667-0196

Doug Wilson



**"ONE MILE AHEAD"**  
*Smith and Jones*  
**Antique Auto Parts**  
60 Wisconsin St., W. Columbia, SC 29170  
803/822-4141 FAX 803/822-8477

Quality Parts  
Same Day Shipping  
Established 1972  
142 Page Catalog  
Order Desk 800-422-1928

[www.snjparts.com](http://www.snjparts.com)



**HAGERTY**  
FOR PEOPLE WHO LOVE CARS



INSURANCE. DRIVERS CLUB. CAR VALUES. DRIVESHARE.  
Drive with us. 800-922-4050 | [hagerty.com](http://hagerty.com)



**J.C. TAYLOR**  
INSURANCE

[www.jctaylor.com](http://www.jctaylor.com)  
800-345-8290

Antiques      Hot Rods & Modifieds      Classic Cars

**MICHAEL J. TAYLOR, JR.**  
CIC, CPIA

3510 WHEELER ROAD  
AUGUSTA, GEORGIA 30909  
706-733-6888  
FAX 706-738-4063

DAWSON, TAYLOR & COMPANY  
INSURANCE  
[mjtj@dtcinsurance.com](mailto:mjtj@dtcinsurance.com)

**Mike's "A" Ford-able Parts**  
**Mike Butcher** 

124 Model A Drive, Maysville, GA 30558  
 email: [mike@mikes-afordable.com](mailto:mike@mikes-afordable.com) - [www.mikes-afordable.com](http://www.mikes-afordable.com)  
 Fax: 706 652 2492 - Phone: 706 652 3866  
 1 888 TRY MIKE (879 6453)



*Specialising in 1928 - 1931 Model A Ford Parts*

The World's Largest Selection of 1909-31 Ford Parts

**Snyder's**  
**ANTIQUE AUTO PARTS**

12925 Woodworth Rd. • New Springfield, OH 44443  
 Toll Free Ordering (888) 262-5712  
 or FAX (888) 262-5713  
 Order On-Line @ [www.snydersantiqueauto.com](http://www.snydersantiqueauto.com)



 **FREE Fully Illustrated CATALOG**  
 \$10.00 outside the U.S., Canada, & Mexico

**Bentley's**  
 Antique Auto Service, Inc.

We are a Full Service Shop, specializing in Model A Fords  
 We offer Award-Winning Paint and Bodywork  
 Expert Service and a Complete Machine Shop

Enjoy the Drive...  
**678-407-1947**

**BRATTON'S**  
 ANTIQUE AUTO PARTS



800-255-1929 Phone  
[www.brattons.com](http://www.brattons.com)  
 800-774-1930 Fax  
 1606 Back Acre Circle  
 Mount Airy, MD 21771

*Your source for Quality Model A Ford Parts since 1976*

**POWDERCOATING**  
 Professional Powdercoating Service

**JAPW Racing Inc.**

200 Rose Street Jimmy Rivers  
 Martinez, GA 30907 706-863-1206  
[info@jrpwrcing.net](mailto:info@jrpwrcing.net)

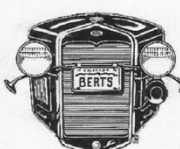

**Bert's Model "A" Ford Center**

2767 S. Tejon, Englewood, CO 80110  
 ph# 303-293-3673 or 800-321-1931  
 email address - [parts@modelastore.com](mailto:parts@modelastore.com)  
[www.modelastore.com](http://www.modelastore.com)

**We buy and sell original and reproduction Model A Ford parts!**



**new**  
 200 page catalog  
 online or by request

**Gaslight Auto Parts**  
 800.242.6491  
[www.gaslightauto.com](http://www.gaslightauto.com)

**1909-48 FORD parts & accessories**  
 since 1962

**GOLDMECH**  
 706.724.GOLD

HEATING · AIR CONDITIONING · PLUMBING