

SHADE TREE A'S

NEWSLETTER

January 2020

Volume 47

Number 1



THE SHADE TREE A'S
MONROE WADE AWARD
PRESENTED TO
Stuart Smith
FOR OUTSTANDING DEDICATION
AS A MEMBER OF
THE SHADE TREE A'S

President Matt Barrett	706-799-3699 pres@ShadeTreeAs.org
Vice President Darrell Henderson	706-863-1673 vp@ShadeTreeAs.org
Secretary Frank Knapp	706-736-5238 sec@ShadeTreeAs.org
Treasurer Richard Dunevent	706-339-8167 treas@ShadeTreeAs.org
Tour Director OPEN	tourdir@ShadeTreeAs.org
National Director Jim McPherson	706-592-4835 nationaldir@ShadeTreeAs.org
Board of Directors Dan Perla	706-855-5730 bod1@ShadeTreeAs.org
Board of Directors Stuart Smith	706-825-9441 bod2@ShadeTreeAs.org
Membership Coordinator OPEN	membership@ShadeTreeAs.org
Newsletter Editor Robbie Jones	706-860-2758 newsletter@ShadeTreeAs.org
Photographer Sheila McPherson	706-592-4835 photographer@ShadeTreeAs.org
Era Fashions Anne Neely-Beck	478-945-3736 erafashions@ShadeTreeAs.org
Webmaster Dan Perla	706-855-5730 webmaster@ShadeTreeAs.org



CONTENTS

Columns

Off the Running Board	3
Meeting Minutes	3
Looking Ahead	
Club Calendar	4
Refreshments	4
Birthdays	4
Announcements	
Shade Tree A's Member News	6
Other Sundry Announcements	6
Recent Events	
Shade Tree A's Annual Christmas Party	7
Model A Story	
My Model A Ford History	9
The Shade Tree A's - Thirty Years Ago	10
Technical Topics	11
Advertisements	12

On the Cover

Shade Tree A's Club President, Matt Barrett, along with Betty Wade, award the 2019 Monroe Wade Award to Stuart Smith at the annual Christmas party.

SHADE TREE A'S MODEL A CLUB



The Shade Tree A's Model A Club is a non-profit organization dedicated to the preservation and the restoration of the Model A Ford automobile. Shade Tree A's annual dues are only \$25. Members are urged to join the Model A Ford Club of America (MAFCA, \$50 annual dues) and the Model A Restorer's Club (MARC, \$45 annual dues) to enjoy the benefits of these national organizations including their respective magazines: *The Restorer* (MAFCA) and *Model A News* (MARC). The Shade Tree A's club is also a member of MAFFI, the Model "A" Ford Foundation, Inc.



CONTACT INFORMATION

4424 Reynolds Street
 Hephzibah GA 30815-7909
 Website: <http://www.ShadeTreeAs.org>
 Facebook: Shade Tree A's Model A Ford Club

ABOUT THIS NEWSLETTER

© 2020 Shade Tree A's, except as noted.
 Please contact Robbie Jones at Newsletter@ShadeTreeAs.org concerning reprinting of articles, illustrations, or photos.

OFF THE RUNNING BOARD

Matt Barrett - President

Greetings fellow club members 🤠

I hope everyone had a wonderful Christmas!

Our STA Christmas party was a huge success! If you missed the festivities, you missed a great time. Fifty members and guests enjoyed delicious food and the ambiance at Jack Sheppard's Country Store. Thank you again, Jack, for the use of your nostalgic facility.

The weather looks like it will cooperate for our New Year's Day breakfast at Cracker Barrel. Let's start the New Year with a big turnout. There will be pics at Shadetreeas.org and in our next newsletter.

I have been thinking that it might be fun to start a new addition to our newsletter in 2020. In a following article, I decided to tell our members how and when I got involved in the Model A "obsession". I'd like to encourage all of you to email me your story - with pictures whenever possible - which will then appear in a future newsletter. I know that you all have fun and interesting accounts of your "journey to obsession" 😊 [Email your stories to the Newsletter Editor too. Ed.]

Be sure to attend the next meeting at Richard's Garage on Monday, January 13th. Our speaker will be Don Patterson, who is quite the expert on antique radios. His presentation should be very interesting, so don't miss this meeting.

Stuart Smith is the 2019 Monroe Wade award winner and a very deserving one. Congratulations to you, Stuart!

Hope to see you in you "A" soon!!!

🎉🎉 HAPPY NEW YEAR 🎉🎉

MEETING MINUTES

There was no December meeting due to the annual Shade Tree A's Christmas Party at Jack Shepard's Country Store; therefore, there are no meeting minutes.



MONTHLY MEETING TIME & LOCATION
Meetings are held on the second Monday of each month at Richard Dunevent's garage, 4338 Owens Road, Evans, GA. Meetings begin at 7:00 PM and are followed by refreshments.



LOOKING AHEAD

Club Calendar

January

- 1 Shade Tree A's New Year's Day breakfast, Cracker Barrel at I-20 and Belair Road, 8:00 AM
- 13 Shade Tree A's Meeting, 7:00 PM, Richard's garage
(Antique radios presented by Don Patterson)

February

- 10 Shade Tree A's Meeting, 7:00 PM, Richard's garage
(Technical Program TBA)

March

- 9 Shade Tree A's Meeting, 7:00 PM, Richard's garage
(Technical Program TBA)
- 21 Palmetto A's Annual Picnic

TBA - To Be Announced

January Refreshments



Ham sliders, potato salad, baked beans and brownies provided by Sheila & Jim McPherson and Dan Perla

January Birthdays



- 7 Mary Griffin
- 20 Leonard McCain
- 24 Edward Griffin
- 29 Heidi Carruthers
- 31 Janet Neumar

ANNOUNCEMENTS

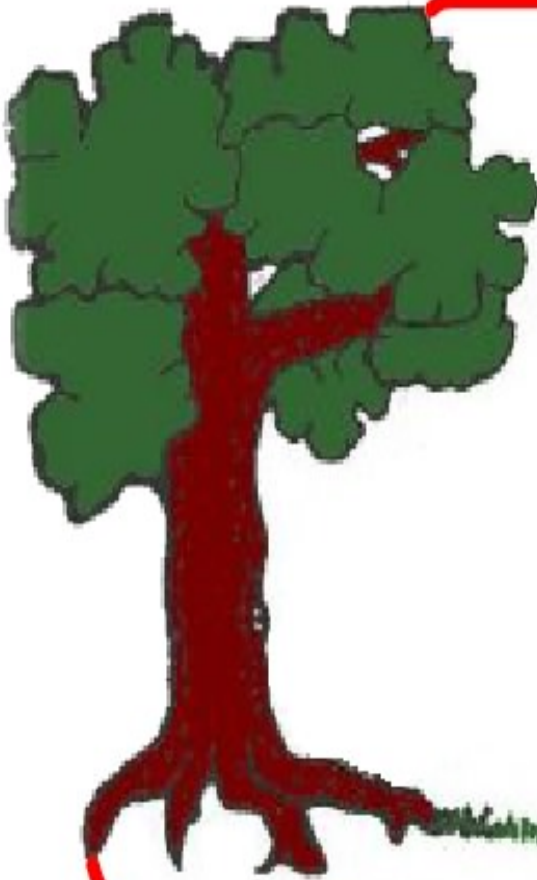

Shade Tree A's Member News

- Congratulations to Stuart Smith for winning the 2019 Monroe Wade Award

*Send items for Shade Tree A's Member News to:
newsletter@ShadeTreeAs.org*

Monthly Technical Program

Got an idea for a technical program for presentation at a monthly meeting?

Got a topic you would like discussed during a monthly technical program?

Do you want to volunteer to present a technical program?

If so, contact Darrell Henderson at vp@ShadeTreeAs.org or 706-863-1673

ANNOUNCEMENTS

Time for a New Shade Tree A's Webmaster

I created the Shade Tree A's website in 1996 inspired by the 1995 MAFCA South East Divisional Meet that our club sponsored. It was also the first SE Divisional MAFCA meet. Now, after over 23 years of maintaining the website, I feel it is time to let someone else contribute to the club by taking over the reins of the website. I will continue to manage the website till the end of March 2020, during which time I will assist whoever takes over. The website hosting is currently paid for until October 2020. If no one volunteers, and the club does not continue to pay for the website, the URL (shadetreeas.org) will be lost after October 2020.

Regards,
Dan Perla

MARC Driving Awards Program Mileage is Now Due

If you are a participant in the Model A Restorer's Club Driving Awards Program, please note your mileage as of December 31, 2019 and provide it to the Shade Tree A's Driving Coordinator, Robbie Jones.

If you are a member of MARC you are eligible to participate in the program. A one-time registration fee of \$1.00 is required. The first award is given at 2,000 miles and every 5,000 miles thereafter. Mileage does not have to be earned all in one year and can accumulate from year to year. Additional information on the program including how to register can be found on the MARC website at:

www.modelaford.org/drivingawards.htm



Shade Tree A's Annual Dues Are Past Due!

If you haven't paid your dues yet, please do so by the January meeting. The Newsletter mailing list will be updated soon to reflect the current roster. Hurry up so you don't miss out on Club news and activities.

Dues are \$25. Checks should be made payable to Shade Tree A's and can be mailed to Dan Perla or Richard Dunevent or brought to the January meeting.

RECENT EVENTS

Shade Tree A's Annual Christmas Party

Saturday, December 14, 2019

Story and photos by Robbie Jones

The annual Shade Tree A's Christmas party was held at Jack Shepard's Country Store. Approximately fifty Shade Tree A's members and their families attended. All enjoyed turkey and dressing with all the fixins - and dessert.

Stuart Smith was awarded the 2019 Monroe Wade Award by Club President, Matt Barrett, and Betty Wade, Monroe Wade's wife. Deborah Fuller, Monroe and Betty's daughter, was also on hand for the award.

Stuart has been active in driving his Model A on local tours, parades, and tours to distant locations and presenting programs at meetings. He frequently shares tips and videos on the repair and restoration of the Model A. He is famous for his video documentation of our tours, both local and long distance. He has served on the Board of Directors and is a frequent attendee of the Shade Tree A's Wednesday Lunch Group and Follow the Quail Tours.

Congratulations Stuart!



Monroe Wade and the Shade Tree A's

New members might wonder who Monroe Wade was. Monroe was a man who loved Model A's and who loved the Shade Tree A's Club! A man you could **ALWAYS** depend on to help a fellow member regardless of the time or weather. Monroe worked hard for the Club and you could usually find him leading a tour or carrying in refreshments or door prizes that he had talked some local business into donating.

After restoring a 1930 Tudor that had belonged to his Mother, Monroe went on to restore a number of other A's. All of them were award-winning cars!

After his death in 2003, his wife Betty and his daughters, Deborah and Joyce, have continued to be active in the Club and to drive Monroe's beloved cars.

Monroe was a great friend and we miss his enthusiasm and his ability to make a Model A purr like a contented kitten.



RECENT EVENTS

Shade Tree A's Annual Christmas Party

Continued



Model A Story

My Model A Ford History

Story and photos by Matt Barrett

In 1962 John F. Kennedy was president, gas was 28 cents a gallon, I was turning 11 years old and this is where my story begins. I had several school classmates that were throwing newspapers and making 15 to 20 dollars per week. That sounded good to me so I applied and got a route near my home. One of my customers happened to have several Model A Fords in their backyard and I inquired if they were for sale. I purchased my first car for 10 dollars down and 10 dollars per week for 9 weeks. At the end of those long weeks, the car was officially mine!! I spent all of my free time tearing the car apart and restoring the chassis. Soon after I found a running 1931 Town Sedan in Blackville, South Carolina for 100 dollars. Since I had no driver's license, my father drove the car to Augusta without a muffler, brakes, working starter and 2 quarts low on crankcase oil. Three weeks later someone saw my car located in my dad's downtown warehouse and offered me 300 dollars but I wasn't having any thoughts of selling my just acquired Model A.

Fast forward 5 years and I had purchased 3 more Fords. One was a 1930 Town Sedan that I purchased off Lumpkin Road for 400 dollars which Bob Jones helped me restore. I traded him the 1931 slant window Town Sedan that now lives at Richard Dunevent's Garage.

In 1980 the mortgage interest rate went to 20 percent so I thought it a good time to sell my last Model A to Joe Holley. Jim McPherson now owns that 1930 Town Sedan 🚗 !!

For many years I was "Model A-less" but I never lost my desire to own another one. That brings us to 2016 when I purchased Chuck Howell's 1930 Tudor Sedan. I have pictures of the "before" and "after" and you can see a striking difference. When it is 100 degrees in July, I tell my wife that driving my A is the most fun I've ever had with my clothes on. 😁



THE SHADE TREE A'S – THIRTY YEARS AGO



The 1985-2005 Shade Tree A's newsletters are now available on the Shade Tree A's website. They can be accessed via the same "button" as the other newsletters, but they are password protected. The same password used to access the member roster is used to access the newsletters. Thank you Dan Perla for scanning these and posting on the website.

The January 1990 issue of the Shade Tree A's Newsletter included instructions for building a Model A tow bar. The Newsletter editor subtly hinted at wanting help with the content of the Newsletter (*hint-hint from the current editor too*). Then Club President, Ralph Neitzke, reflected on the Club's activities in 1989, such as tours, delivery of toys to Toys for Tots, and helping other Club members sand, paint and assemble Model A cars and trucks.

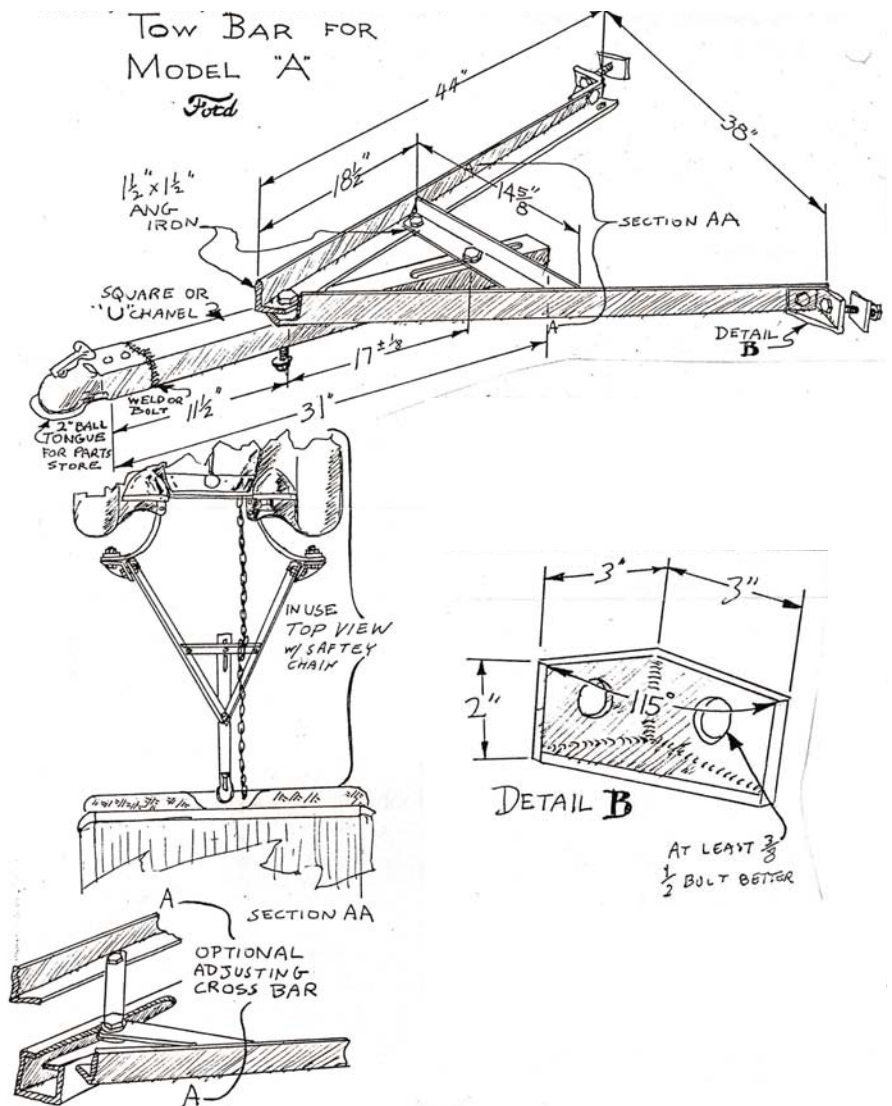

TECHNICAL TOPICS

Clean Those Wheels

Originally submitted by Tony Topicz and previously published in the AaaOOOgah newsletter, Ohio Valley Region.

Here is a very simple and easy way to clean spoked wheels. Buy a good brand of "Foam Bathroom Cleaner" to spray on your wheels. After spraying, wait a few minutes to let the cleaner soak in and to penetrate the dirt. Rinse off with a garden hose and you should have clean and shiny wheels.

Front Wheel Bearing Installation and Adjustment

Jim's Tech Tip - Model A Ford Club of America

1. See that front hub, inner and outer bearings are packed with grease.
2. Front hub washer should slide over threads on spindle body with fingers (loose fit).
3. Install nut and tighten it while slowly turning the brake drum so that all component parts are pulled together snugly; that is, inner and outer bearings will be snug in cones, washer is tight against outer roller bearing, and nut tight against washer. (There will be a slight drag when drum is turned.) Not over 8-10 ft-lbs of torque is required to get these results.
4. Turn nut BACK two castle slots (this is approximately 1/4 turn of nut); insert cotter pin and try bearings for a slight side play and a free spinning drum or wheel.



Don't forget the cotter pin! The nut will back out and the wheel will come off. That will totally spoil your Model A Day!

Cooling System Treatment

By Robbie Jones



While at the Shade Tree A's Christmas Party, I was talking to Paul Ianuario, Ernie Dinkins' brother-in-law. He told me about a cooling system treatment that greatly reduced the temperature of his early Ford V-8 car. It's called RMI-25 Cooling System Treatment. The product was originally developed for and used by commercial fleet operators. According to their website:

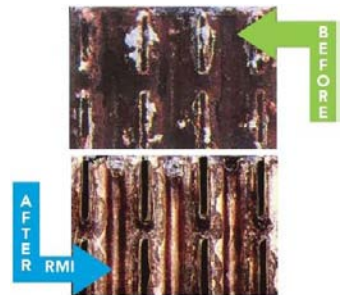

It cleans while you drive; inhibits rust, cavitation erosion, electrolysis and pitting; lubricates water pump seals and thermostats; and improves cooling.

If you're having cooling system problems, you may want to consider this product. If you do use RMI-25, let us know about your experience.

Member Advertisements

Deadline for submittal – 20th of the month – Send submittals to newsletter@ShadeTreeAs.org

- Original Model A Instruction Books (Owner’s Manual). Prices based on condition, \$25 to \$195.
Don Turley, Call 706-863-4867, leave a message and I will return your call. Or email don@donturley.com

- Engine stand, \$25 OBO, Robbie Jones



- Set of four tires for 1928-1929 Model A Fords (those years having 21 inch wheels.) These are bias ply Firestone whitewalls, less than 2 years old, with less than 1,000 miles on them. They are in excellent condition. Selling just the tires, not the wheels. I am asking \$525 (Price Reduced) - they sell new for just under \$900. Email: Eddie Collins, 1947collins@gmail.com. Eddie is the newsletter editor for the LowCountry Model A Ford Club in Charleston.

Paid Advertisements



Allstate.
You're in good hands.
Personalized Service.
Trusted advice.

E Walker Crosby
Agency Owner

Allstate Insurance Company
1890 Huntsman Drive
Aiken, SC 29803

Phone 803-642-6560
Fax 803-642-6561
walkercrosby@allstate.com
allstateagencies.com/walkercrosby
M-F 8:30 to 5:30 Weekends by appt.
Auto, Home, Life, Retirement



Bentley's

Antique Auto Service, Inc.

We are a Full Service Shop, specializing in Model A Fords

We offer Award-Winning Paint and Bodywork

Expert Service and a Complete Machine Shop

Enjoy the Drive...

678-407-1947

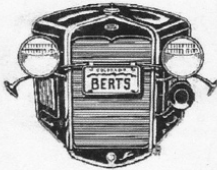

Bert's Model "A" Ford Center

2767 S. Tejon, Englewood, CO 80110
ph# 303-293-3673 or 800-321-1931
email address - parts@modelastore.com
www.modelastore.com

We buy and sell original and reproduction Model A Ford parts!

BRATTON'S

ANTIQUe AUTO PARTS



800-255-1929 Phone
www.brattons.com
800-774-1930 Fax
1606 Back Acre Circle
Mount Airy, MD 21771

Your source for Quality Model A Ford Parts since 1976

BUY • SELL • TRADE



GERALD JONES
AUTO GROUP

CLICKAROO.COM

1003 ALEXANDER DRIVE
AUGUSTA, GA 30909

P.O. BOX 212072
MARTINEZ, GA 30917

D&M 
D'Antignac & Merritt Heating & Air, Inc.

Turn To The Experts.

(706) 667-0196 Doug Wilson

Furniture Doctor Inc.
Since 1980
Augusta, Georgia

RESTORATION SHOP
www.furnituredoctor.net

Estimates for . . .

- Insurance Claims
- Military Claims
- Moving Damage

Restoration by Professionals with Over 50 Years of Experience

Bruce Smith
Office: 706-793-0716
Fax: 706-793-3776
3345 Peach Orchard Road
Augusta, GA 30906
restoration@furnituredoctor.net

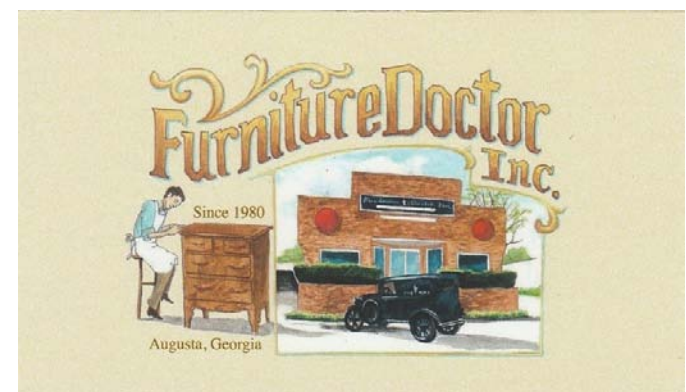

Furniture Doctor Inc.
Since 1980
Augusta, Georgia

SALES & SUPPLIES
www.furnituredoctor.net

Providing Services for
Estate Liquidations

Complete Line of Refinishing Supplies for Professional and Do-It-Yourselfers

Walter Smith
Office: 706-798-5951
Fax: 706-798-7658
3323 Peach Orchard Road
Augusta, GA 30906
supplies@furnituredoctor.net

new
200 page catalog
online or by request

Gaslight Auto Parts
800.242.6491
www.gaslightauto.com

1909-48 FORD parts & accessories
since 1962

 **HAGERTY**
FOR PEOPLE WHO LOVE CARS

INSURANCE. DRIVERS CLUB. CAR VALUES. DRIVESHARE.
Drive with us. 800-922-4050 | hagerty.com

GOLDMECH
706.724.GOLD
HEATING · AIR CONDITIONING · PLUMBING

**FAIRWAY FORD IS YOUR
BEST PRICED
FORD DEALER**
706-854-9200 | FairwayFordAugusta.com



POWDERCOATING
Professional Powdercoating Service
JRPW Racing Inc.
200 Rose Street
Martinez, GA 30907
info@jrpwracing.net

Jimmy Rivers
706-863-1206

Joseph E. Spires
ATTORNEY-AT-LAW

Ward & Spires, LLC
445 Walker Street
Augusta, Georgia 30901

Phone (706) 724-2640
Facsimile (706) 724-2642
E-mail: Wardspires@aol.com



**J.C. TAYLOR
INSURANCE**
www.jctaylor.com
800-345-8290



Antiques Hot Rods & Modifieds Classic Cars

Mike's "A" Ford-able Parts
Mike Butcher 

124 Model A Drive, Maysville, GA 30558
email: mike@mikes-afordable.com - www.mikes-afordable.com
Fax: 706 652 2492 - Phone: 706 652 3866
1 888 TRY MIKE (879 6453)



Specialising in 1928 - 1931 Model A Ford Parts

MICHAEL J. TAYLOR, JR.
CIC, CPIA

3510 WHEELER ROAD
AUGUSTA, GEORGIA 30909
706-733-6888
FAX 706-738-4063

DAWSON, TAYLOR & COMPANY
INSURANCE
mjtj@dtcinsurance.com

"ONE MILE AHEAD"
Smith and Jones
Antique Auto Parts
60 Wisconsin St., W. Columbia, SC 29170
803/822-4141 FAX 803/822-8477



Quality Parts
Same Day Shipping
Established 1972
142 Page Catalog
Order Desk 800-422-1928

www.snjparts.com

The World's Largest Selection of 1909-31 Ford Parts

Snyder's
ANTIQUÉ AUTO PARTS

12925 Woodworth Rd. • New Springfield, OH 44443
Toll Free Ordering (888) 262-5712
or FAX (888) 262-5713
Order On-Line @ www.snydersantiqueauto.com



 **FREE Fully Illustrated CATALOG**
\$10.00 outside the U.S., Canada, & Mexico