

# SHADE TREE A'S

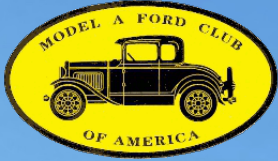

## NEWSLETTER



October 2022

Volume 49

Number 10



4424 Reynolds Street  
Hephzibah GA 30815-7909  
Website: <http://www.ShadeTreeAs.org>

<b>President</b> Jim McPherson	706-592-4835 pres@ShadeTreeAs.org
<b>Vice President</b> John Neumar	706-386-2980 vp@ShadeTreeAs.org
<b>Secretary</b> Frank Knapp	706-736-5238 sec@ShadeTreeAs.org
<b>Treasurer</b> Stuart Smith	706-825-9441 treas@ShadeTreeAs.org
<b>Tour Director</b> Charles Weaver	706-373-9422 tourdir@ShadeTreeAs.org
<b>National Director</b> Matt Barrett	706-799-3699 nationaldir@ShadeTreeAs.org
<b>Board of Directors</b> Dan Perla	706-855-5730 bod1@ShadeTreeAs.org
<b>Board of Directors</b> Darrell Henderson	706-863-1673 bod2@ShadeTreeAs.org
<b>Membership Coordinator</b> Frank Knapp	706-736-5238 membership@ShadeTreeAs.org
<b>Newsletter Editor</b> Robbie Jones	706-860-2758 newsletter@ShadeTreeAs.org
<b>Photographer</b> Sheila McPherson	706-592-4835 photographer@ShadeTreeAs.org
<b>Era Fashions</b> Anne Neely-Beck	478-945-3736 erafashions@ShadeTreeAs.org
<b>Webmaster</b> Dan Perla	706-855-5730 webmaster@ShadeTreeAs.org



## CONTENTS

### Columns

Off the Running Board	3
Meeting Minutes	3
Club Calendar	5
<b>Announcements</b>	
Shade Tree A's Member News	6
Refreshment Schedule	6
Birthdays	6
Other Sundry Announcements	7
<b>Recent Events</b>	
International Model A Ford Day Tour	12
Model A Era Fashion and Style	13
Just For Fun	14
The Shade Tree A's - Thirty Years Ago	15
Technical Topics	16
Advertisements	18

### On the Front Cover

The Shade Tree A's participated in the Polish N Parts car show for International Model A Ford Day. John Buchanan drove his 1929 Tudor Sedan to the show. Photo by Darrell Henderson. Story and more photos on page 12.

## SHADE TREE A'S MODEL A CLUB

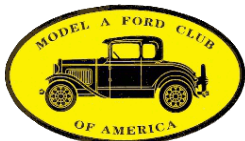

The Shade Tree A's Model A Club is a non-profit organization dedicated to the preservation and the restoration of the Model A Ford automobile. Shade Tree A's annual dues are only \$25. Members are urged to join the Model A Ford Club of America ([www.mafca.com](http://www.mafca.com)) and the Model A Restorer's Club ([www.model-a-ford.org](http://www.model-a-ford.org)) to enjoy the benefits of these national organizations including their respective magazines: *The Restorer* (MAFCA) and *Model A News* (MARC). The Shade Tree A's club is also a member of MAFFI, the Model "A" Ford Foundation, Inc.



#### CONTACT INFORMATION

4424 Reynolds Street  
 Hephzibah GA 30815-7909  
 Website: <http://www.ShadeTreeAs.org>

#### ABOUT THIS NEWSLETTER

© 2022 Shade Tree A's, except as noted.  
 Please contact Robbie Jones at [Newsletter@ShadeTreeAs.org](mailto:Newsletter@ShadeTreeAs.org) concerning reprinting of articles, illustrations, or photos.

## OFF THE RUNNING BOARD

*Jim McPherson - President*

We had another outstanding program at our September meeting. Dan Perla presented the program on vacuum windshield wipers. When was the last time you attended a program complete with patent drawings and operational diagrams and a video of an operating vacuum wiper? In celebration of International Model A Day several members drove their Model A. Some drove to, or attended the Polish 'n Parts Car Show and some just drove their Model A on a beautiful summer day.

At the October meeting Andrew Morse and Dan Perla will present the program on THE Hershey Experience. Dan will be able to compare Hershey 2022 to past Hershey meets. We will have a Tech Session on Saturday October 22 (rain date October 29). We will be having a Swap Meet at Andrew Morse's shop (1818 Augusta Rd. Dearing) from 8AM to 2PM. This is your chance to sell parts you bought to repair your Model A and didn't use, or maybe some parts that came with your Model A when you bought it. Other members might need those parts to repair their Model A. So join us for a day of fellowship and Model A's. For lunch we will be having hamburgers and hot dogs.

We are approaching the end of the year and we have several items on our Calendar. That means it is time for dues. Treasures Stuart Smith will be collecting dues (\$25) at the meeting, or mail them to him at 3535 West Lake Dr., Martinez, GA 30907-8931. We will hold our annual Christmas Party at Jack Shepard's. It will be catered by Wife Savers. The cost will be \$20 per person. Dan Perla will be accepting your reservation and payment at the meeting or by mail (454 Fulcher Dr., Martinez, GA 30907-8766). Nominations for the Monroe Wade Award are due. See the details in this Newsletter.

## MEETING MINUTES

*September 12, 2022*

*Richard's Garage*

*Respectfully submitted: Frank Knapp - Secretary*

The monthly meeting of The Shade Tree A's was held September 12, 2022 in the clubhouse meeting room at Richard Dunevent's garage. President Jim McPherson brought the meeting to order promptly at 7:00 P.M. Twenty-seven members were in attendance.

Matt Barrett offered our "Joke of the Month".

President:

President Jim welcomed all members especially Tom & Kathy Poole, both long time members.

Vice President:

John Neumar had nothing to report.

Treasurer:

Stuart Smith reported our Treasury remains unchanged. A motion was made from the floor to accept the Treasurer's Report. That motion received a second and was passed by unanimous vote.

National Director:

Matt Barrett asked members to send him any interesting information concerning STA activities to be published in *The Restorer*.

Newsletter Editor:

Robbie Jones was not in attendance; therefore, no report was given.

Show & Tell:

Matt Barrett passed around an Eagle Safety Oil Can made of solid brass. A very Interesting item labeled "Patent Applied For".

# MEETING MINUTES

*Continued*

**Tour Director:**

In the absence of Charlie Weaver, Andy Morse reminded the group of the Polish N Parts car show to be held Saturday, September 17<sup>th</sup>. Attendance to this event will also serve to qualify for International Model A Day participation patches which will be passed out at that event.

**Old Business:**

President Jim reported our "Breakfast Tour" held August 27<sup>th</sup> was quite a success. The tour was well attended and all enjoyed shopping at the new Northern Tool & Equipment outlet.

**New Business:**

President Jim announced he has appointed Pat Riley to be our Wayne Ready Memorial Library custodian. Pat will be reviewing the books we have on hand and ordering more recent publications as needed.

Jim McPherson, Dan Perla and Darrel Henderson will serve as our 2023 Nominating Committee. Members are urged to contact the Committee if interested in serving in any capacity.

Stuart Smith will soon be collecting Club dues for the year 2023. Be on the look-out for a message from Stuart.

The Christmas Party has been set for Saturday, December 3<sup>rd</sup>. Once again it will be held at Jack Shepherd's excellent facility. Cost will be \$20.00 per person.

Deborah Fuller announced her group of "historical volunteer ladies" will be holding a festival in Willington, S.C. on Saturday, October 1<sup>st</sup>. Her group would appreciate having Model A's present if anyone plans to attend.

**Technical Program:**

Dan Perla's Power Point presentation concerning Trico Vacuum Windshield Wipers was enjoyed by all. Dan covered the parts and operation of both versions available for the Model A. All info and diagrams were obtained from the original patents and/or the Trico Wiper Manuel. Well done. Thanks Dan!

There being no further business, the meeting was adjourned at 7:55 P.M. after which a refreshing array of ice-cream, cake and soft drinks were provided by Darrell & Sybil Henderson, Richard Dunevent and "yours truly". Special thanks to Sybil for her "homemade" confections. Delicious!

**MONTHLY MEETING TIME & LOCATION**

Meetings are held on the second Monday of each month at Richard Dunevent's garage, 4338 Owens Road, Evans, Georgia. Meetings begin at 7:00 PM and are followed by refreshments.

## CLUB CALENDAR

### *Shade Tree A's Events*

#### October

- 10 Shade Tree A's Meeting, 7:00 PM, Richard's garage (Technical Program - *The Hershey Experience*, presented by Andrew Morse and Dan Perla)
- 22 Saturday Technical Session - Shade Tree A's Club Swap Meet, 8:00 AM to 2:00 PM, at Andrew Morse's shop, 1818 Augusta Hwy (Hwy. 278), Dearing, GA. Lunch will be served. Rain date October 29.

#### November

- 14 Shade Tree A's Meeting, 7:00 PM, Richard's garage (Technical Program - *The Model AA Truck Collection of Steve Teal*, presented by Steve Teal)

#### December

- 3 Shade Tree A's Christmas Party at Jack Shepard's, catered by Wife Saver, Dan Perla is accepting reservations and \$20 payment per person at the Club meeting or by mail (454 Fulcher Dr., Martinez, GA 30907-8766).

#### Every Wednesday at 11:30

Join the Shade Tree A's for lunch at Cicis Pizza on Wheeler Road

***TBA - To Be Announced***

### *Other Events of Interest*

#### October

- 3-7 AACA Eastern Fall National, Hershey, PA (note the schedule change for this year - Monday through Friday)

#### December

- 5-8 2022 Model A Ford Club of America National Awards Banquet, Golden, CO

# ANNOUNCEMENTS

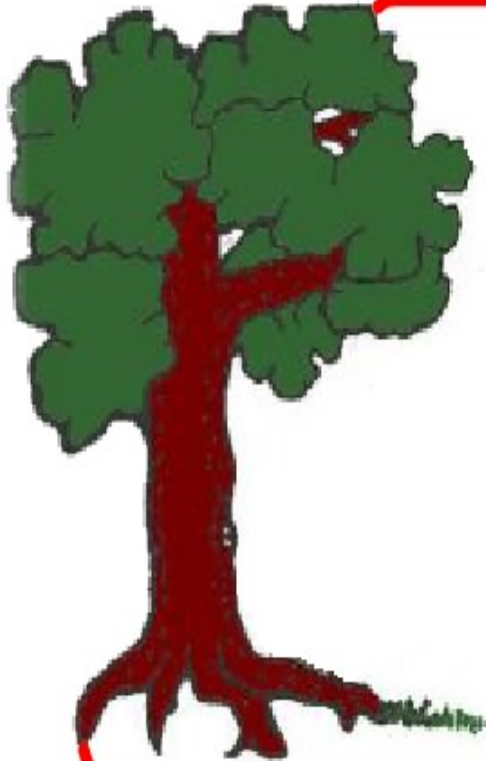

## Shade Tree A's Member News

- Richard Dunevent is at home recovering from a recent illness
- Betty Wade is recovering from recent surgery
- Please remember the family of Walker Mobley, long time member of the Shade Tree A's, who passed away September 8, 2022

Send items for Shade Tree A's Member News to: [newsletter@ShadeTreeAs.org](mailto:newsletter@ShadeTreeAs.org)



## Refreshment Schedule

October  
**Charlie Weaver Sr. and Charlie Weaver Jr.**  
November  
**Kenny Adkins, Darren Riley**  
December  
**No Refreshments - Christmas Party**



## October Birthdays

- 2 Leslie Holley
- 3 Shelby Deitz
- 5 Anne Neely Beck
- 6 Rita Spencer
- 7 Syble Henserson
- 8 Suzanne Gordon
- 8 Jim McPherson
- 14 Andrew Morse
- 17 Leta Jones
- 25 Sheila Wilson

## ANNOUNCEMENTS

### In Memory of Walker Mobley

The Shade Tree A's lost a long-time member, Walker Mobley, on September 8, 2022. Although Walker did not currently own a Model A, he enjoyed being around our special cars and will be greatly missed. The following is his obituary as published in the Augusta Chronicle:

Entered into to rest on Thursday, September 8, 2022, Mr. G Walker Mobley, Jr., 82, son of the late Annie Laurie Mobley and loving husband of 42 years to Margaret Ann Mobley. Walker was a lifelong resident of Augusta, GA. He graduated from the University of Georgia and was a mechanical engineer at Kimberly Clark for many years. Walker enjoyed rebuilding motorcycles and cars. He took great pleasure in refurbishing bicycles for Augusta Urban Ministries. He was a loving husband, father and grandfather.

Family members in addition to his wife include his sons: Walker Mobley and John Mobley (Jennifer); grandchildren: Kian Mobley and Dax Mobley; brother-in-law: Jay Harper (Pat); sister in law: Meme Asserson; and cousin: Sara Lee Harwell.

The graveside service will be held Tuesday, September 13, 2022, at 11:00 am at Westover Memorial Park with Rev. Roy McVeigh officiating.

Memorial contributions may be made to Trinity on the Hill Methodist Church Music Ministry, 1330 Monte Sano Avenue, Augusta, GA 30904.

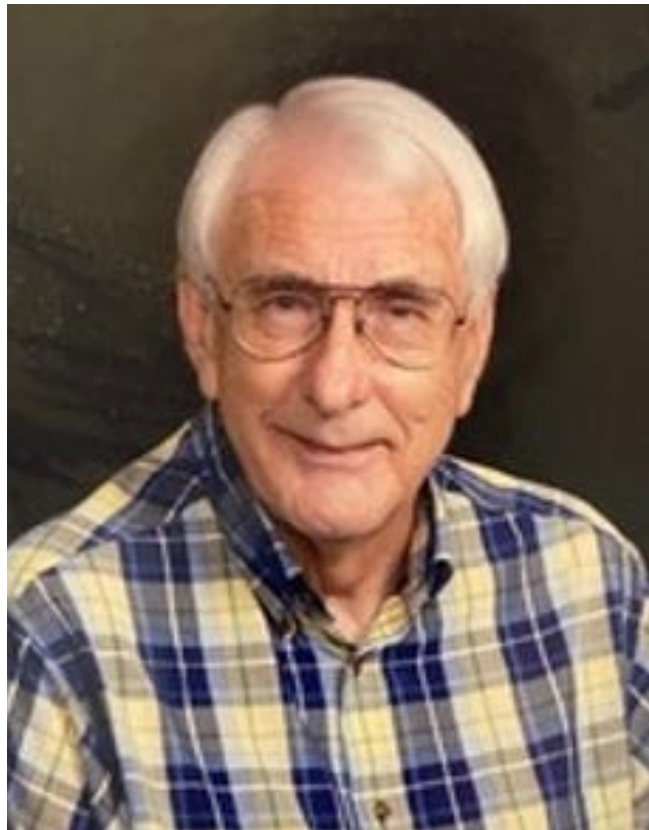

## ANNOUNCEMENTS

### 2022 Monroe Wade Award Nominations

It's that time of year for the members of the Shade Tree A's to make their nominations for the Monroe Wade Award. The Monroe Wade Award honors a current Shade Tree A's member who promotes and encourages the furtherance of the Model A hobby. The member can have accomplished this in any of the ways listed below:

- A Club member who goes out of his or her way to help other members repair or maintain their Model A's.
- A Club member who:
  - a. Writes an outstanding article for the Shade Tree A's Newsletter regarding repair and restoration, or who brings to light new information about the Model A.
  - b. Presents an outstanding program regarding repair and restoration or who provides new information about the Model A at a Club meeting.
- A Club member who shows dedication to the Model A hobby and to the Club by:
  - a. Driving his or her Model A on a substantial number of Club tours and events.
  - b. Driving his or her Model A great distances, demonstrating that the Model A is not only fun but a worthy means of transportation.
  - c. Is an outstanding representative of the Shade Tree A's at national meets and tours or local community events, thus serving as a Shade Tree A's club ambassador.

### Monroe Wade and the Shade Tree A's

New members might wonder who Monroe Wade was. Monroe was a man who loved Model A's and who loved the Shade Tree A's Club! A man you could **ALWAYS** depend on to help a fellow member regardless of the time or weather. Monroe worked hard for the Club and you could usually find him leading a tour or carrying in refreshments or door prizes that he had talked some local business into donating.

After restoring a 1930 Tudor that had belonged to his Mother, Monroe went on to restore a number of other A's. All of them were award-winning cars!

After his death in 2003, his wife Betty and his daughters, Deborah and Joyce, have continued to be active in the Club and to drive Monroe's beloved cars.

Monroe was a great friend and we miss his enthusiasm and his ability to make a Model A purr like a contented kitten.

The annual award is our way of remembering Monroe and we are delighted to have Betty and the Wade family to be active in the Club.





## ANNOUNCEMENTS

### 2022 Monroe Wade Award Nominations

Club members may nominate any member in good standing by **submitting the member's name and a short paragraph with their reasons for nominating the member.** The winner will be announced at the annual Christmas party. The award winner's name will be added to a permanent plaque located at the Club's meeting place and a second plaque will be given to the winner.

The winner will be chosen by a committee that includes Betty Wade, Monroe's wife. You may give your nomination to one of the committee members listed below. All nominations must be received **not later than the November meeting** (November 14, 2022) to be considered

Don Turley (Chairman) 706-589-0738  
donturley@knology.net

Andrew Morse 706-834-2342  
4morses@comcast.net

Stuart Smith 706-825-9441  
stuartsmith3535@yahoo.com

Betty Wade 706-830-0059  
bettywade@comcast.net

Please take time to seriously consider nominating one of our outstanding members for this year's Award.



## ANNOUNCEMENTS

Model A Ford  Club of America

250 SO. CYPRESS • LA HABRA, CALIFORNIA 90631-5586  
562/697-2712 • 562/697-2737 • FAX 562/690-7452



*The Prez Sez...*

September 2022

I would like to call your attention to the upcoming MAFCA Election of officers for 2023. The candidates have been approved by the board, their Biographical material has been submitted and you will see it the next Restorer. Your ballots will be arriving soon. Included in the mailing you will find your membership renewal forms. I would like to encourage you to study the candidates' qualifications and VOTE for the five who you feel will represent you best. I urge you vote as soon as you receive the ballots and renew your membership promptly. By sending in your ballots and renewal form, you will help our office staff to get the membership renewal process done efficiently.

As we enter the month of September, there are many Fun events ahead. I am looking forward to attending Model A Days at the Model A Ford Foundation Museum in Hickory Corners, Michigan. This year's dates are September 16<sup>th</sup> and 17<sup>th</sup>. The swap-meet promises to hold many treasures, several seminars will teach and inform us, and a few surprises are instore. I am planning to spend time at our MAFCA Information booth where we will have some of our new products for sale. Later in the day, will be the annual induction ceremony for the Model A Ford Hall of Fame.

A few short weeks later, October 3<sup>rd</sup> through 7<sup>th</sup>, will be the Hershey Fall Meet. We will have our usual tent there with seminars, sale items and fun. I would like to invite you to stop by and see our display and meet Sandra, our business manager and several of our Board members.

The Chapters of MAFCA are where the Rubber Meets the Road. These club meetings are where friendships are developed, it has been fun to visit many meetings this year. I have enjoyed seeing clubs conduct their business, present programs, hold raffles for Model A items, and enjoy refreshments. The bottom-line regarding club meetings it to make them a fun activity that your members want to attend. One club provided name tags so when someone new attended, they were self-introduced. It has been rewarding to watch MAFCA Grow this year.

As always, I am happy to help you. Please feel free to send me an email at [president@mafca.com](mailto:president@mafca.com).  
Happy Motoring, Jay McCord

# ANNOUNCEMENTS

2022 National  
Awards Banquet  
December 5-8  
Golden, Colorado



Join us in beautiful Golden, Colorado at the Table Mountain Inn.

Visit Clear Creek History Park, the Buffalo Bill Museum, the Colorado Railroad Museum, the Coors Brewery, the Rocky Mountain Quilt Museum, and The Clive Cussler Museum.

Something for everyone!

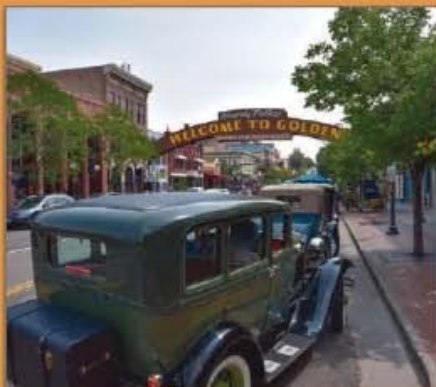

# RECENT EVENTS

## International Model A Ford Day Tour

*Story by Jim McPherson*

*Photos by Matt Barrett and Darrell Henderson*

International Model A Day was established to honor Henry Ford's dedication of a new Ford factory in England and his subsequent tour of factories in Europe. It is a day in which Model A owners are asked to drive their Model A. What is important is not the destination, but the fact that you drove your Model A. The Shade Tree A's had several members drive their Model A on Saturday September 17<sup>th</sup> in recognition of International Model A Ford Day. Darrell and Syble Henderson in their 1930 Tudor Sedan, John Buchanan in his 1929 Tudor Sedan and Dan Perla in his 1931 SW Cabriolet drove their Model A's and participated in the Polish N Parts Car Show at the James Brown Arena. Charlie Weaver Sr. drove his 1931 SW Town Sedan, Matt Barrett drove his 1930 Tudor Sedan, Craig and Theresa McMullin drove their 1930 Fordor Sedan, and Eric Shogren drove his 1928 Special Coupe. All received an International Model A Ford Day patch for their efforts.



Matt Barrett



Darrell Henderson



Darrell Henderson

# MODEL A ERA FASHION AND STYLE

## Bouquets on Bonnets

By Sherry Winkinhofer, Northwest Missouri Model A Ford Club

The hats and bonnets worn in the Model A era came in a myriad of shapes, colors, and designs. These colorful hats could be decorated with ribbons, beads, pins, feathers, and more! A favorite decorative element often used were flowers or other floral and nature-based designs. Hats with flower trimmings were available in all major catalogs as well as stores and millinery shops.

Read the full article on the MAFCA Website at [http://www.mafca.com/ef\\_articles.html](http://www.mafca.com/ef_articles.html) and learn how hats and flowers complimented each other during the Model A years!

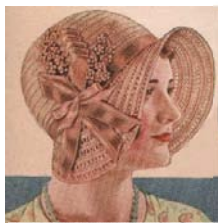

National Bellas Hess Co  
Spring and Summer  
1931

plush flowers



National Bellas Hess Co  
Spring and Summer  
1931

Velvet flowers



The Robert Simpson  
Catalog Fall and Winter  
1928-29

Velvet orchid



Sears Roebuck and Co Fall and  
Winter 1928-29

sheer organdy and rayon plush



Sears Roebuck and Co  
Fall and Winter 1928-29

Organdy and rayon taffeta

Catalogs such as Sears and Montgomery Wards sold separate flowers and floral collections that could be used freshen up old hats or add to new hats and garments. It seems odd that most of time these catalogs showed them in black and white, but just a few color ads are to be found to help demonstrate the vivid colors that were available.



Sears, Roebuck and Co  
Spring and Summer 1928

Handmade fabric flowers



National Bellas Hess Co Inc  
Spring and Summer 1931

Applied plush flowers



The Robert Simpson Co  
Fall and Winter 1928-29

Plush blossoms with  
tinsel stitching



Robert Simpson catalog Fall and Winter 1928-

Below are some "New-Old-Stock" (NOS) flower trimmings from an era Millinery supply.



Picture from collection of Patti Jones

JUST FOR FUN

Model 'A' Crossword Puzzle

Complete the crossword puzzle below

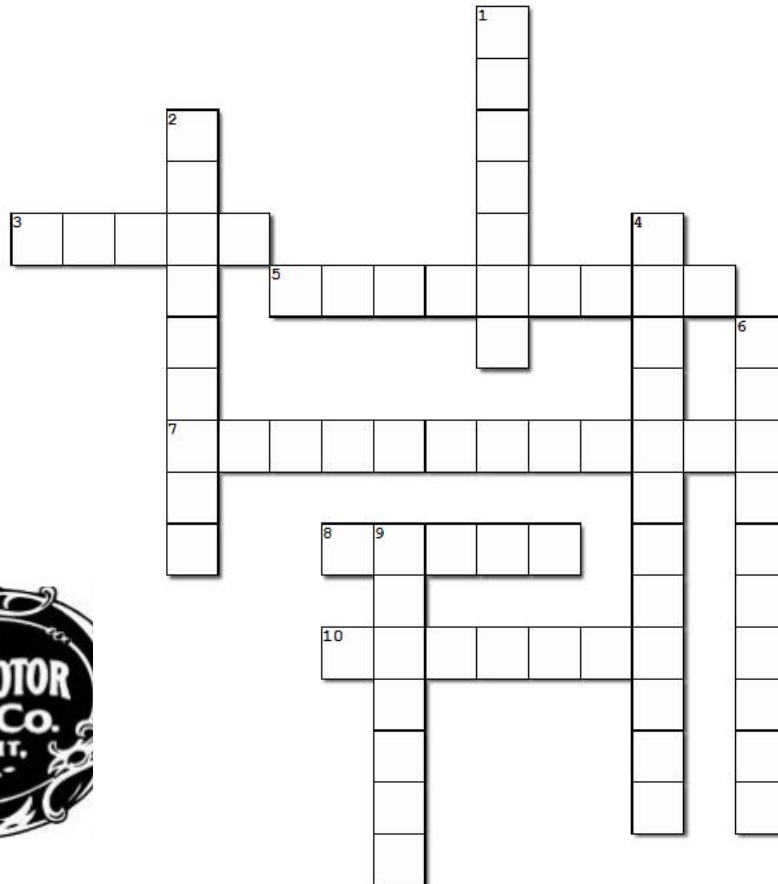

Created using the Crossword Maker on TheTeachersCorner.net

**Across**

- 3. Will get that Model 'A' started
- 5. After market Model 'A' Carburetor
- 7. 19 or 21
- 8. National Club initials
- 10. Inside a Zenith carburetor

**Down**

- 1. A Model 'A' that occasionally goes topless
- 2. Stores electricity temporarily
- 4. What your Model 'A' Loves
- 6. The guy who designed and lobbied for the Model 'A'
- 9. Old style grease fittings

Answers on the next page

## THE SHADE TREE A'S – THIRTY YEARS AGO



The 1985-2005 *Shade Tree A's Newsletters* are now available on the Shade Tree A's website. They can be accessed via the same "button" as the other *Newsletters*, but they are password protected. The same password used to access the member roster is used to access the *Newsletters*. Thank you Dan Perla for scanning these and posting on the website.

The October 1992 issue of the *Shade Tree A's Newsletter* included an article originally published in Volume 1, Issue 1 of the *Model A Inquirer* about Frankie Dunevent. An article describing a bad experience ordering from a Model A parts vendor reminds us to be careful when ordering from not so well known vendors. The *Newsletter* also included a long article on Sunday drivers in pre-1905 cars.



## Answers to the Model 'A' Crossword Puzzle

### Across

3. Will get that Model 'A' started (**crank**)
5. After market Model 'A' Carburetor (**tillotson**)
7. 19 or 21 (**spoke wheels**)
8. National Club initials (**mafca**)
10. Inside a Zenith carburetor (**venturi**)

### Down

1. A Model 'A' that occasionally goes topless (**phaeton**)
2. Stores electricity temporarily (**condenser**)
4. What your Model 'A' Loves (**to be driven**)
6. The guy who designed and lobbied for the Model 'A' (**edsel ford**)
9. Old style grease fittings (**alemite**)

## TECHNICAL TOPICS

### Jim's Tech Tips

#### "Grease Fitting Added to 7-tooth Steering Gear"

The Ford Service Bulletin from September, 1928, has a brief mention of adding a grease fitting to the sector shaft housing of the 7-tooth steering gear. Today's Tech Tip is a reprint of that little article from that bulletin.

FORD SERVICE BULLETIN for September

PAGE 28 I

#### NEW LUBRICATOR FITTING IN STEERING GEAR HOUSING

The drilled hole in the steering sector shaft, through which the lubricant in the steering gear housing was carried to the sector shaft bushings, has been discontinued. Sector shaft bushings are now lubricated by means of a lubricator fitting placed in the steering gear housing. (See A, Fig. 570.) Lubricant should be forced into this fitting every 2,000 miles.

Should an instance arise where it is necessary to install the present design sector in an old steering gear assembly, it will be necessary to install a lubricator fitting in the housing. This is done by drilling a  $21/64$ " hole  $2-3/32$ " back from center line of flange where housing is bolted to frame. (See Fig. 571.) The hole should be drilled through housing and sector bushing and then tapped with a standard  $1/8$ " pipe tap. When tapping the hole, do not tap too deep. The hole should be tapped just deep enough so that when the lubricator fitting is screwed down tightly approximately two threads on the fitting will remain above the surface of the housing. (See Fig. 571.)

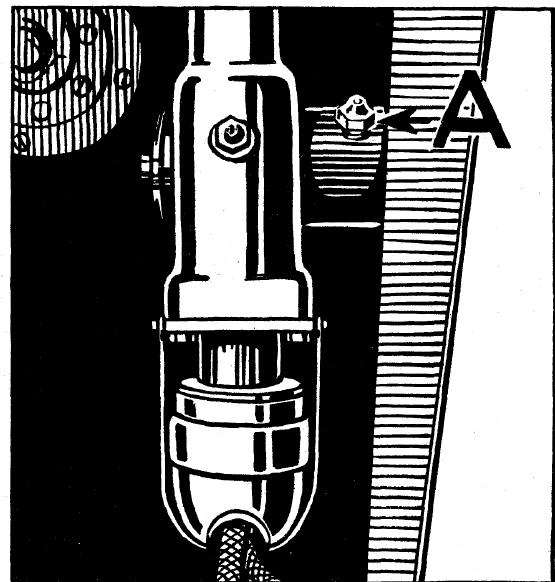
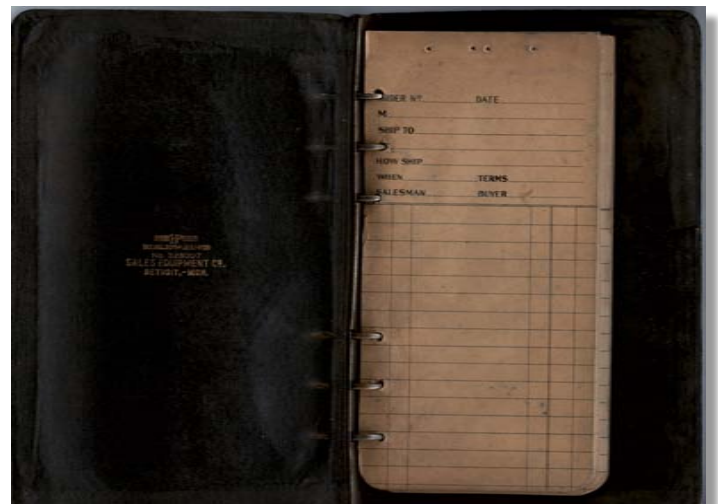

Fig. 570

### Model A Sales Booklet

Story and photo by Jim McPherson

This is an original Salesman Order Book for the Model A Ford, showing the inside cover and order form. The cover is too worn to copy, but it says *Fordex, Salesman Order Book*. This company provided many specialty forms in books like this one for Ford Motor Company and their dealers, including a data book, 3 Day Sales Report, 20 Day Sales Report, and a 10 Day Color Report (reporting the color of the car sold).





## TECHNICAL TOPICS

# Smith Model A Motor Compressor

The Hagerty Insurance Company recently published a nice article on air compressors manufactured from Model A Ford engines by the Gordon Smith & Company Inc. The article includes plenty of pictures of various compressors in use and figures from Gordon Smith's patent application. The full article can be viewed at the following web address:

[https://www.hagerty.com/media/automotive-history/when-america-reinvented-a-ford-to-get-stuff-done/?utm\\_source=SFMC&utm\\_medium=email&utm\\_content=MED\\_UN\\_NA\\_EML\\_UN\\_DailyDriver\\_Tuesday&hashed\\_email=0766af19ccff88eae0fa45775ff00685125c9d8cf4e2030b893a6808c5330a03](https://www.hagerty.com/media/automotive-history/when-america-reinvented-a-ford-to-get-stuff-done/?utm_source=SFMC&utm_medium=email&utm_content=MED_UN_NA_EML_UN_DailyDriver_Tuesday&hashed_email=0766af19ccff88eae0fa45775ff00685125c9d8cf4e2030b893a6808c5330a03)

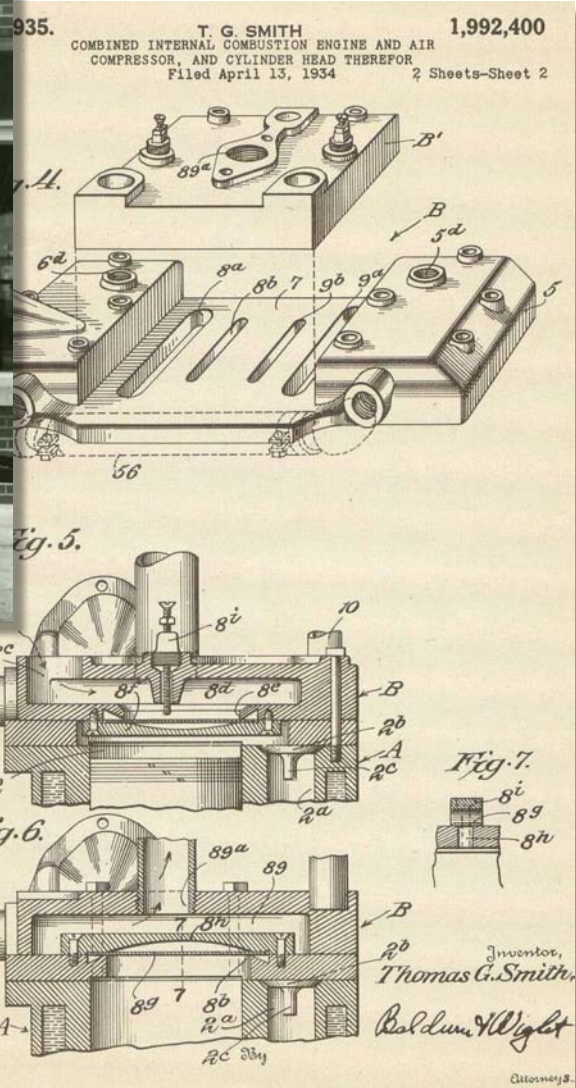

### Member Advertisements

Deadline for submittal – 20<sup>th</sup> of the month – Send submittals to [newsletter@ShadeTreeAs.org](mailto:newsletter@ShadeTreeAs.org)

#### FOR SALE

Larry Brumfield head. Pictures available. Bought several years ago from Larry Brumfield. Head was trued two years ago. Came as 5.2, not certain after leaving the machine shop, runs good. All original paper work, \$300

Original distributor have been using as a spare, ready to drop in. \$100

Contact Abbie Prince

**SOLD**

Six-volt alternator, used. Works great. \$85 **[Price Reduced!]** (I replaced mine with one of the new alternators that looks like an original generator.)

Restored original Stewart Warner horn. Sounds great! \$225

Ford script Model 'T' tire pump, steel, painted black. \$80.

Pair of very rough condition 1930-31 plain front fenders (no spare tire wells). One left, one right. Will require a lot of work, or cut them up to use as patch panels to repair other fenders. \$20 each fender.

Contact Don Turley 706-589-0738

### Paid Advertisements

#### SHADE TREE A'S NEWSLETTER SPONSORS

*Our thanks to the following sponsors! Their generosity supports this Newsletter and the Shade Tree A's! Please remember these folks when you need a service they offer. And please, tell them you appreciate their support of our Club!*

**Bentley's**  
Antique Auto Service, Inc.

We are a Full Service Shop, specializing in Model A Fords  
We offer Award-Winning Paint and Bodywork  
Expert Service and a Complete Machine Shop  
Enjoy the Drive...

**678-407-1947**



**Bert's Model "A"  
Ford Center**

2767 S. Tejon, Englewood, CO 80110  
ph# 303-293-3673 or 800-321-1931  
email address - parts@modelastore.com  
www.modelastore.com

**We buy and sell original and reproduction Model A Ford parts!**

**BRATTON'S**  
**ANTIQUE AUTO PARTS**



800-255-1929 Phone  
[www.brattons.com](http://www.brattons.com)  
 800-774-1930 Fax  
 1506 Back Acre Circle  
 Mount Airy, MD 21771

*Your source for Quality Model A Ford Parts since 1976*

1003 ALEXANDER DRIVE  
 AUGUSTA, GA 30909

P.O. BOX 212072  
 MARTINEZ, GA 30917

**D&M**   
**D'Antignac & Merritt Heating & Air, Inc.**  
 Turn To The Experts.

(706) 667-0196 Doug Wilson

**FAIRWAY FORD IS YOUR  
 BEST PRICED  
 FORD DEALER**

706-854-9200 | [FairwayFordAugusta.com](http://FairwayFordAugusta.com)



**FAIRWAY**  
 FORD/EVERANS GEORGIA

**POWDERCOATING**  
 Professional Powdercoating Service

**JAPW Racing Inc.**

200 Rose Street  
 Martinez, GA 30907  
[info@jrpwrcing.net](mailto:info@jrpwrcing.net)

Jimmy Rivers  
 706-863-1206

**Mike's "A" Ford-able Parts**  
**Mike Butcher** 

124 Model A Drive, Maysville, GA 30558  
 email: [mike@mikes-afordable.com](mailto:mike@mikes-afordable.com) - [www.mikes-afordable.com](http://www.mikes-afordable.com)  
 Fax: 706 652 2492 - Phone: 706 652 3866  
 1 888 TRY MIKE (879 6453)



*Specialising in 1928 - 1931 Model A Ford Parts*

**"ONE MILE AHEAD"**  
*Smith and Jones*  
 Antique Auto Parts  
 60 Wisconsin St., W. Columbia, SC 29170  
 803/822-4141 FAX 803/822-8477



Quality Parts  
 Same Day Shipping  
 Established 1972  
 142 Page Catalog  
 Order Desk 800-422-1928

 [www.snjparts.com](http://www.snjparts.com)

The World's Largest Selection of 1909-31 Ford Parts

**Snyder's**  
**ANTIQUE AUTO PARTS**

12925 Woodworth Rd. • New Springfield, OH 44443  
 Toll Free Ordering (888) 262-5712  
 or FAX (888) 262-5713  
 Order On-Line @ [www.snydersantiqueauto.com](http://www.snydersantiqueauto.com)



 **FREE Fully Illustrated CATALOG**  
 \$10.00 outside the U.S., Canada, & Mexico

**Joseph E. Spires**  
 ATTORNEY-AT-LAW

Ward & Spires, LLC  
 445 Walker Street  
 Augusta, Georgia 30901

Phone (706) 724-2640  
 Facsimile (706) 724-2642  
 E-mail: [Wardspires@aol.com](mailto:Wardspires@aol.com)