

# SHADE TREE A'S



## NEWSLETTER

June 2023

Volume 50

Number 6



4424 Reynolds Street  
Hephzibah GA 30815-7909  
Website: <http://www.ShadeTreeAs.org>



<b>President</b> Craig McMullin	803-341-8955 pres@ShadeTreeAs.org
<b>Vice President</b> Andrew Morse	706-834-2342 vp@ShadeTreeAs.org
<b>Secretary</b> Frank Knapp	706-736-5238 sec@ShadeTreeAs.org
<b>Treasurer</b> Stuart Smith	706-825-9441 treas@ShadeTreeAs.org
<b>Tour Director</b> Charles Weaver	706-373-9422 tourdir@ShadeTreeAs.org
<b>National Director</b> Matt Barrett	706-799-3699 nationaldir@ShadeTreeAs.org
<b>Board of Directors</b> Darren Riley	803-230-9510 bod1@ShadeTreeAs.org
<b>Board of Directors</b> Jim McPherson	706-564-0120 bod3@ShadeTreeAs.org
<b>Membership Coordinator</b> Frank Knapp	706-736-5238 membership@ShadeTreeAs.org
<b>Newsletter Editor</b> Robbie Jones	706-860-2758 newsletter@ShadeTreeAs.org
<b>Photographer</b> Sheila McPherson	706-592-4835 photographer@ShadeTreeAs.org
<b>Era Fashions</b> Anne Neely-Beck	478-945-3736 erafashions@ShadeTreeAs.org
<b>Webmaster</b> Dan Perla	706-855-5730 webmaster@ShadeTreeAs.org

## CONTENTS



<b>Columns</b>	
Off the Running Board	3
Meeting Minutes	3
Club Calendar	5
<b>Announcements</b>	
Shade Tree A's Member News	6
Refreshment Schedule	6
Birthdays	6
Other Sundry Announcements	7
<b>Recent Events</b>	
Shade Tree A's 50 <sup>th</sup> Anniversary	10
Johnston Peach Blossom Parade	11
Four A's and a T	13
Model A Era Fashion and Style	15
The Shade Tree A's - Thirty Years Ago	16
Technical Topics	17
Advertisements	19

### On the Front Cover

The Shade Tree A's celebrated their 50<sup>th</sup> anniversary at the Augusta Museum of History on June 3, 2023. Friends from the Aiken Model A Ford Club, the Low Country Model A Ford Club, the Old 96 District Model A Club and the Southside A's Model A Club joined us for this very special occasion. Peoples Choice Awards were presented for 1928, 1929, 1930, 1931 and commercial Model A Fords. Henry Ford was on hand to answer anyone's questions about himself or the Model A Ford automobile. Due to publication deadlines, more comprehensive coverage of the event will appear in the July 2023 issue of the Newsletter. Photo by Robbie Jones



## SHADE TREE A'S MODEL A CLUB

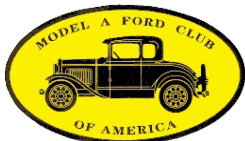

The Shade Tree A's Model A Club is a non-profit organization dedicated to the preservation and the restoration of the Model A Ford automobile. Shade Tree A's annual dues are only \$25. Members are urged to join the Model A Ford Club of America ([www.mafca.com](http://www.mafca.com)) and the Model A Restorer's Club ([www.model-a-ford.org](http://www.model-a-ford.org)) to enjoy the benefits of these national organizations including their respective magazines: *The Restorer* (MAFCA) and *Model A News* (MARC). The Shade Tree A's club is also a member of MAFFI, the Model "A" Ford Foundation, Inc.



**CONTACT INFORMATION**

4424 Reynolds Street  
 Hephzibah GA 30815-7909  
 Website: <http://www.ShadeTreeAs.org>

**ABOUT THIS NEWSLETTER**

© 2023 Shade Tree A's, except as noted.  
 Please contact Robbie Jones at [Newsletter@ShadeTreeAs.org](mailto:Newsletter@ShadeTreeAs.org) concerning reprinting of articles, illustrations, or photos.

## OFF THE RUNNING BOARD

*Craig McMullin - President*

I would like to thank all those that provided their support, advice, time and energy to make the Shade Tree A Model A Ford Club 50<sup>th</sup> Anniversary a memorable event. We had 48 Model A's registered for the display and over 100 club members and their guests attend the event, plus many more from the general public.

Our host, the Augusta Museum of History, provided the perfect venue and location in downtown Augusta, GA.

- Many thanks to Robbie Jones for displaying his beautiful 1931 Model A Slant Window Deluxe Fordor Sedan in the museum rotunda. It made for a beautiful display.
- Congratulations to all those that received a Peoples Choice Award.
- And a big Thank You to Doug Skinner for impersonating Henry Ford. During the event Doug answered all the questions about the man himself and the history of the Model A Ford.
- The event Sponsor was Gerald Jones Ford Auto Group that made a generous monetary donation and provided the gift bags for all the registrants.

An event like this could not happened again without the support of all the Shade Tree A members and the many individuals and area businesses that made donations or provided goods and services.

Thanks again and Congratulations to the Shade Tree A's Model A Ford Club for reaching such an historic milestone. Let's set the groundwork NOW for the next 50 Years!

Ahooga,  
Craig McMullin - President

## MEETING MINUTES

*May 8, 2023*

*Richard's Garage*

*Respectfully submitted: Frank Knapp - Secretary*

The monthly meeting of The Shade Tree A's was held May 8, 2023 in the clubhouse meeting room at Richard Dunevent's garage. The meeting was called to order by President Craig McMullin at 7:00 PM welcoming all 31 members in attendance. Three members, who will remain anonymous, contributed to our "Name Tag Cup" for failure to display proper identification!

Matt Barrett offered our joke of the evening and President Craig noted all nineteen April birthdays. Happy Birthday to all!

Vice President:

Andrew Morse announced our technical program for the evening will be presented by Gerald Melchiors on rebuilding Model A Shocks. Andrew also asked for more technical program ideas from the membership.

Treasurer:

Stuart Smith reported no deposits were made in April. Expenditures totaling \$232.70 were paid to President Craig, Sheila McPherson and Kevin Parrish, CPA for anniversary expenses, Saturday Tech Session lunches and tax return filing respectively.

A motion was made and seconded to approve The Treasurer's Report and the April Minutes as published in *The Newsletter*. That motion passed by unanimous vote.

*Continued on next page*

### MONTHLY MEETING TIME & LOCATION

Meetings are held on the second Monday of each month at Richard Dunevent's garage, 4338 Owens Road, Evans, Georgia. Meetings begin at 7:00 PM and are followed by refreshments.

# MEETING MINUTES

*Continued*

### National Director:

Matt Barrett reminded members to take note of STA activities published in the May/June issue of *The Restorer*.

### Newsletter Editor:

Robbie Jones commented on an article in *The Newsletter* concerning Georgia Tech's "Ramblin Wreck". More info below under Show & Tell.

### Tour Director:

No report given.

### Show & Tell:

Robbie passed around a new book by Steve Plucker on Model A assembly plants from 1928 to 1931. He also commented on the article he published in our April newsletter concerning a new home for The Ramblin' Wreck, Georgia Tech's 1930 Sport Coupe. Robbie plans to visit "The New Dream Garage" facility in the near future and will report on his visit at a later date.

### Old Business:

President Craig opened a discussion concerning April club tours asking for input from those who participated. Tours of interest included the Old 96 Swap Meet, Saturday Tech Session, Kiokee Baptist Cruise-in and the Johnston Peach Parade.

Craig also reviewed plans for our June 3<sup>rd</sup> Anniversary Celebration. In addition to revealing our new Anniversary Banner he passed around examples of the patches, nametags and car plaques to be given to all participants. So far, eighty-five guests and forty car registrations have been received.

### New Business:

The group was reminded of several upcoming activities. All members were encouraged to

attend the Boss Hog Bar-B-Q cook-off, Josh Dover's Low Country Boil, the Aiken Memorial Day Parade and the Palmetto A's Swap meet in the upcoming weeks.

Matt Barrett presented the Model A Restorers Club 2022 Award of Continuing Excellence to Robbie Jones as editor for the *Shade Tree A's Newsletter*.



Photo by Deborah Fuller

### Technical Program:

Gerald Melchior presented another of his detailed programs on repairing and rebuilding Model A Shocks. Aided by our A/V expert, Dan Perla, Gerald explained every process from disassembly to reassembly. Thanks Gerald for another excellent program!

There being no further business, the meeting was adjourned at 9:00 PM after which members were treated to a variety of finger foods, brownies and soft drinks. Big thanks to Kent Carruthers and Robbie Jones for providing.

**CLUB CALENDAR**

***Shade Tree A's Events***

**June**

- 12 Shade Tree A's Meeting, 7:00 PM, Richard's garage (Technical Program - *Speedometer Repair*, presented by Darren Riley)
- 24 Shade Tree A's Technical Session - Kathy Poole's Model A: installing a Quail radiator cap, horn, crankshaft pulley, and new tires; Steve Spencer's Model A: evaluating the brake system and installing a new tire. Lunch will be served, Richard's garage, 9:30 AM.

**July**

- 10 Shade Tree A's Meeting, 7:00 PM, Richard's garage (Technical Program - *The Model A Distributor*, presented by Eric Shogren)
- 22 Shade Tree A's Technical Session - Rebuilding Model A Distributors, presented by Eric Shogren. Lunch will be served, Richard's garage, 9:30 AM.

**August**

- 17 Shade Tree A's Annual Dinner, Sconyer's Bar-B-Que, 6:00 PM in the large room upstairs (Note that there is no regular meeting this month)

**Every Wednesday at 11:30**

Join the Shade Tree A's for lunch at Cicis Pizza on Wheeler Road  
***TBA - To Be Announced***

***Other Events of Interest***

**June**

- 16-17 Palmetto A's Swap Meet, Smith & Jones, Columbia, SC

**July**

- 30 - August 4 MARC National Meet, Hamilton, OH

**September**

- 6-10 Charlotte AutoFair, Charlotte, NC
- 15-16 MAFFI Swap Meet, Hickory Corners, MI
- 16 Parts N Polish Car Show, Forest Hills Storage, 3134 Wrightsboro Rd., 9:00 AM to 2:00 PM

**October**

- 3-6 AACA Eastern Fall Meet, Hershey, PA
- 14 Warren Reynold's Annual Yard Sale, 8:00 AM Until, Rain or Shine, 120 Stoker Road, Greenwood SC, 864-980-7937 or 864-980-0708, swreynolds@centurylink.net
- 22-27 Revival AACA Glidden Tour, Thomasville, GA

**November**

- 16-19 Swap Meet, Moultrie, GA

# ANNOUNCEMENTS

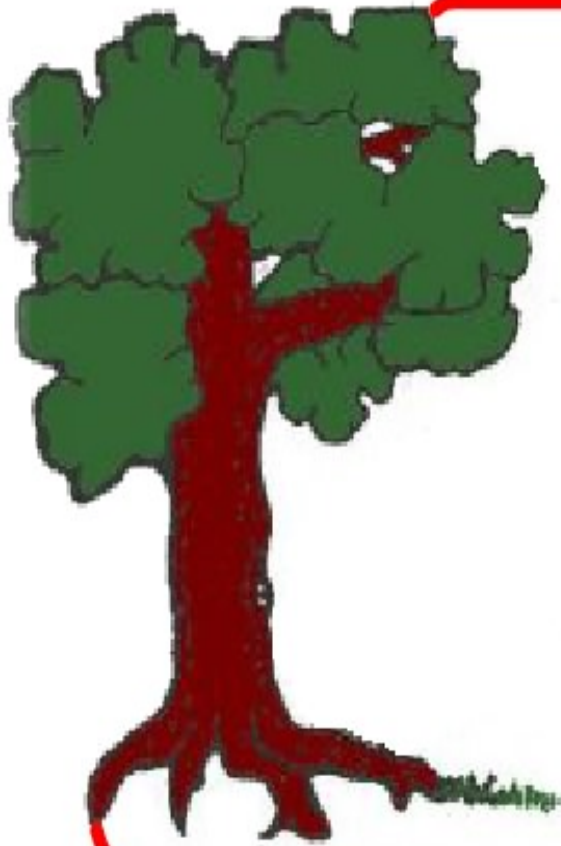

## Shade Tree A's Member News

- Please continue to keep the following Shade Tree A's members in your thoughts and prayers:
  - Syble Henderson
  - Brandon Carter recovering from recent illness
  - Pat Hughes recovering from a recent injury
- Although not a Shade Tree A's member, Ralph Roub's wife of the Old 96 District Model A Ford Club has had some serious health issues lately. Please keep her in your prayers as well.
- Betty Wade recently celebrated her 94<sup>th</sup> birthday. It was great to see her at the Shade Tree A's 50<sup>th</sup> Anniversary celebration. Congratulations and a belated Happy Birthday Betty.

Send items for Shade Tree A's Member News to:  
newsletter@ShadeTreeAs.org



## Refreshment Schedule

June  
 Don Gordon, Misty Hooker, Bob Reis

July  
 Darren & Pat Riley, Kenny Adkins,  
 Steve Spencer

August  
 No refreshments due to Annual  
 Dinner at Sconyer's Bar-B-Que



## June Birthdays

- 1 Darla Summers
- 4 Brandon Carter
- 6 Matt Barrett

ANNOUNCEMENTS

18th Annual

ALL Model A & Model T

SWAP MEET & CAR DISPLAY

at

Smith & Jones Antique Auto Parts
60 Wisconsin St. West Columbia, SC



sponsored by

Palmetto A's of South Carolina

Friday, June 16, 2023 8am to 5pm Swap Meet

Saturday, June 17, 2023 8am to 3pm Swap Meet & Car Display

Vendor Space: Early registration: \$15/one day \$25/two days \$20/\$30 at the gate

Car Corral: \$10 for two days

Palmetto A Members - Free Vendor Space

\$2 Door Prize Tickets Food Concession 50/50

Contact: Dick Fraser at 803-622-7582

dickfraser@earthlink.net

Vendor Sign Up Form

Name: \_\_\_\_\_

Address \_\_\_\_\_

City \_\_\_\_\_ State \_\_\_\_\_ Zip \_\_\_\_\_

Telephone \_\_\_\_\_ email \_\_\_\_\_

Will you be arriving and setting up on Thursday, June 23? \_\_\_\_\_

Are you primarily a Model A or Model T Vendor? \_\_\_\_\_

Please mail this form along with a check or money order made payable to:

Palmetto A's of SC--- 113 Ian Dr. Leesville, SC 29070

By participation in this event and signing this form I/we agree to hold harmless

The Palmetto A's of SC Model A Club, Smith & Jones Antique Auto Parts and any of the members or agents thereof, in the event of accident or injury to any participant, person or group.

Signature \_\_\_\_\_ Date \_\_\_\_\_

## **ANNOUNCEMENTS**

### **Message from MAFCA Chapter Coordinator**

I attended my first Model "A" meeting in the summer of 2005. I had just purchased a 1931 Deluxe Coupe at an auction and I was looking for help with getting it back on the road. I remember that first meeting and how I was anxious about that first encounter with people I did not know. I know that experience is repeated many times across all of our chapters around the world. Fortunately I was greeted at the door with a friendly smile and a handshake and made to feel welcome. That first impression went a long way in making me an 18 year ambassador of this hobby.

For this article I would like to share some words from last year's Chapter Coordinator, Robert Bullard and past President and Chapter Coordinator Doug Linden. These simple steps will help ensure your guests at their first meeting will feel welcome.

- Make sure the Chapter President or Membership Director introduces them to the entire club and encourages the new members/guests to say a few words about themselves, their car(s) and why Model A's interest them.
- Encourage existing members to introduce themselves and interact with the new members/guests to make them feel wanted and included.
- Some Chapters have a "New Member" packet that contains amongst other items: copy of the Chapter by-laws, copy of a current Chapter roster, a current Chapter newsletter, information about MAFCA including a membership application and a list of upcoming Chapter meetings and tours. If you don't have one you should consider creating one for the future.
- Many existing members will be wearing their Chapter nametags so provide a temporary name tag for the "newbies". This will aid in preventing brain cramps and forgetting a name at the worst possible moment.

Your first impression is a valuable tool in attracting and retaining new members. We are all facing declining membership due to the aging of our hobby. Don't waste an important opportunity to make a lifelong impression. That first meeting may be planting the seeds for a longtime and perhaps future officer of your local club.

Former webmaster Rick Black is looking for dimensions of the Hubley tracks that have been built for races at regional and national events. If you can help Rick with the dimensions so he can build the track for their upcoming event give him a shout. [Rickblack44@gmail.com](mailto:Rickblack44@gmail.com)

Looking forward to seeing you on the road,  
Will Langford



## ANNOUNCEMENTS

### Model A Ford Foundation Inc. MAFFI Minute, June 2023



Planning for MAFFI **Model A Days 2023** is nearing completion. Of course, there will be a swap meet, seminars, memorabilia sales, rides, Model A driving classes, and a dinner tour. Hotel rooms have been blocked for our guests. It will be a mix of the old and proven with a few new twists. **September 15 & 16** are the days. Visit the MAFFI or Gilmore web pages, register and make your reservations.

For those who have attended before, Model A Days at Hickory Corners is a wonderful ending to the summer season and beginning of the fall season. It is a chance to see and touch some wonderful old cars, to see what has been changed or added to the museum. There are few places like the Gilmore complex. You can sit in the shade of a maple tree and eat a sandwich and ice cream purchased from a diner converted from an old-time streetcar. While doing this you can talk with friends and look at the vintage cars.

“Huff & Puff”, the Model AA school bus, will be giving rides. The theme this year will be open cars, so look for a phaeton or roadster to be giving rides around the campus. Finally, the AA stake bed truck should be moving the remainder of the passengers around the streets.

This is a great chance to visit with a large group of fellow Model A'ers, one last time before the seasons force us to choose to move most of our activities indoors.

If you are one of the many Model A Club members who will not be able to attend our event, remember September 16, is a Saturday. Use the day to have your own local Model A Day celebration with a tour, or picnic, or both, with your club. A joint tour with a neighboring club might be exciting.

Happy motoring,  
Mike DuBreuil  
MAFFI Board of Trustees  
Secretary  
[clubcontact@maffi.org](mailto:clubcontact@maffi.org)

## RECENT EVENTS

# Shade Tree A's 50<sup>th</sup> Anniversary Celebration

*Story and photos by Robbie Jones*

The Shade Tree A's celebrated their 50<sup>th</sup> anniversary on June 3, 2023 in big style at the Augusta Museum of History. Due to publication deadlines, more extensive coverage of this momentous event will be deferred to the July 2023 issue of the *Shade Tree A's Newsletter*. As part of this "more extensive coverage", I would like to have short stories from as many Shade Tree A's members as possible about their experience at the celebration event. It doesn't have to be much, just a few sentences. Please send your input to me as soon as possible. Until then, here's a few photos from the day's events.



## RECENT EVENTS

### Johnston Peach Blossom Parade

*Story and photos by Craig McMullin*

Eight Model A's representing the Aiken Model A Club and the Shade Tree A's traveled to Johnston, SC on Saturday May 5th for the annual Johnston Peach Blossom Parade. The group met sharply at 8:45 AM at the local NAPA store for pre-parade breakfast biscuits and coffee. Following coffee and biscuits the group was treated to the "behind the scene" operations of not only the huge NAPA enterprise but the adjoining Log Creek Timber Company business and repair facility and Spanky's a full service auto diagnostic and repair facility. These 3 business all operate under one roof owned and operated by the William's family who reside in Edgefield, SC. After the facility tour, the group traveled about 1 mile to the parade lineup location and were met with a few sprinkles that ended within about 10 minutes. The parade was well attended and the cars travelled without incident. Following the parade a few cars met at a reserved Model A parking lot in the center of town on display to the public.



RECENT EVENTS

Johnston Peach Blossom Parade

*Continued*



## RECENT EVENTS

### Four A's and a T

*Story by Matt Barrett*

*Photos by Matt Barrett (this page) and Stuart Smith (next page)*

On May 16<sup>th</sup>, four STA members arrived at Brandon Wilde for a show and tell. One resident, Larry Edison, displayed his grandfather's 1919 Model T Ford. Steven Spencer arrived in his 1930 Coupe as well as Frank Knapp in his 1931 Coupe. Stuart Smith was in his 1931 Deluxe Roadster and yours truly in my 1931 Victoria Leatherback. Estimates of attendees ranged from fifty to one hundred with everyone having a great time. Hot dogs and coke floats were served. There were a lot of smiling faces and several residents approached me to say they were born the same year as our cars! Overall, this was a great show and tell and I look forward to a repeat performance.



RECENT EVENTS



MODEL A ERA FASHION AND STYLE



## THE SHADE TREE A'S – THIRTY YEARS AGO

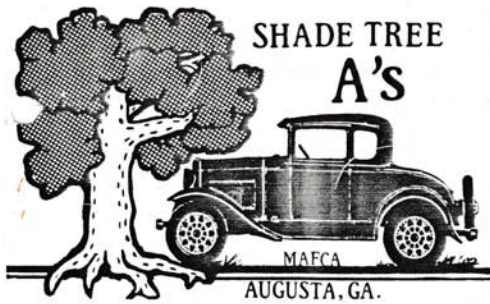

The 1985-2005 Shade Tree A's Newsletters are now available on the Shade Tree A's website. They can be accessed via the same "button" as the other Newsletters, but they are password protected. The same password used to access the member roster is used to access the Newsletters. Thank you Dan Perla for scanning these and posting on the website.

Since the Shade Tree A's just celebrated their 50<sup>th</sup> anniversary, it should come as no surprise that 30 years ago the 20<sup>th</sup> anniversary was the major topic of discussion. In Recognition of this major milestone, a special monthly meeting was planned for June 14<sup>th</sup> for some long-term members to discuss what the Club was like in the early years... How the Club has grown... and, a few pictures of some of our more memorable moments. Club members were encouraged to bring items of interest or an interesting story concerning the Club's history.

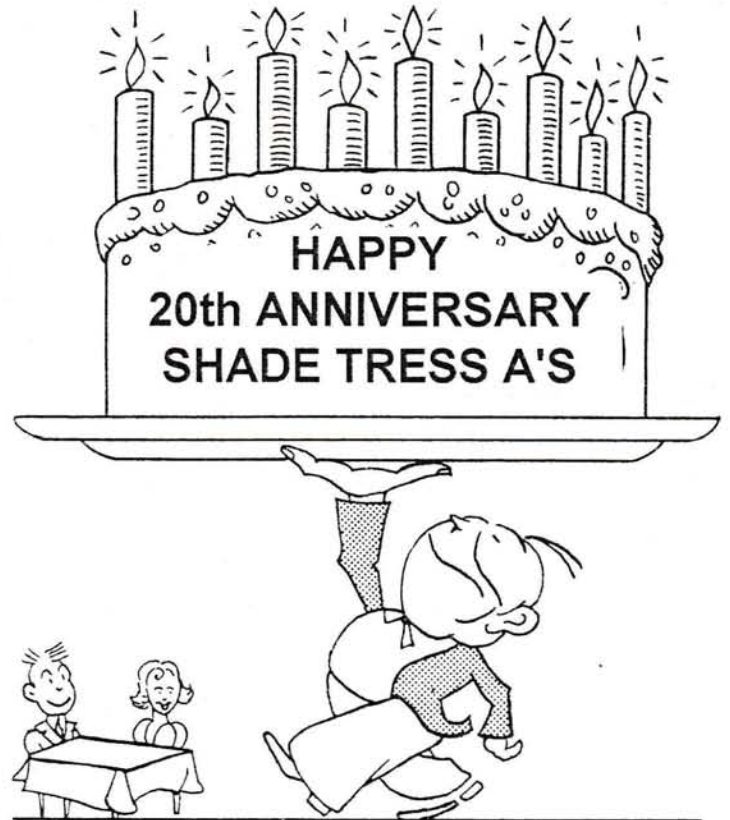

Results of the Road Rally organized by Frank Knapp and Craig McMullin were provided. The rally was proclaimed as a well-planned and enjoyable tour. Also provided was an article on the recent tour to Redcliffe Plantation led by Monroe and Betty Wade in their 1931 Coupe. Frank Knapp drove his Speedster which was an immediate hit as evidenced by the number of kids climbing all over it and the number of people having their picture taken with it.

It was reported that Bob Jones [the Editor's father] was getting his 1931 Blind Back Fordor Sedan ready to show at the MARC National Meet in Winston-Salem. Other Shade Tree A's members also planning on attending included the Adams family, the McPherson's and Don Turley. An article by Jim McPherson described member Ed Meloan's search for a closed car for cold weather touring. Jim also provided an article on original starter switches. An article was also reprinted describing the propane-fueled 1929 Model A Speedster competing in the Great American Race.



## TECHNICAL TOPICS

### Houdaille Shock Absorber Patents

*By Robbie Jones*

I thoroughly enjoyed Gerald Melchior's Technical Program on rebuilding Model A shock absorbers at the May meeting. The patent numbers stamped on the shock absorber covers intrigued me so I thought I would try to find them. The three patent numbers are 1087017, 1426115 and 1499660.

Patent number 1087017 was issued to Maurice Houdaille on February 10, 1914 for "certain new and useful improvements in shock absorbers". These improvements include devices for:

1. The automatic filling of any empty spaces or vacuum that may be produced for any reason in any apparatus in which liquids circulate, particularly shock absorbers for vehicles
2. Adjusting the initial resistance of the shock absorbing apparatus to a given load and regulating the variation of the resistance

Patent number 1426115 was issued to Albert B. Shultz of Buffalo, New York on August 15, 1922. It is unclear if Mr. Shultz is associated with the Houdaille Company. One of the objects of this patent relates to a shock absorber that exerts practically no checking or shock absorbing effect during the middle of the stroke, thus avoiding interference with the free, easy riding of an automobile when traveling over a comparatively even roadway, but which offers considerable resistance at both ends of the stroke when the automobile is traveling over comparatively rough roads.

Patent number 1499660 was issued to Maurice Houdaille on July 1, 1924 for "improvements in liquid shock-absorbers operating by circulation of liquid the braking of which results from the resistance it encounters when passing through calibrated orifices". These improvements more particularly relate to:

1. The arrangement of the stuffing box insulating the shock-absorbing liquid from the exterior
2. The centering of the members guiding the axis of the damping blades and the lubrication of this axis in its bearing
3. The device of recovery of the shock-absorbing liquid after it has lubricated the friction parts
4. The arrangement of the air exhaust valve
5. The arrangement of compensating valves for the shock-absorbing or damping liquid
6. The arrangement on the movable braking members or on the fixed partitions limiting the work-chambers, of safety valves allowing the suppression of the super-pressures and tending to uniformly distribute on each blade the total braking stress
7. The arrangement of ribbed-shoes for guiding the blades

Gerald mentioned a lot of these features and improvements during his Technical Program. The drawings on the next page are a few of the drawings from the patents which show some of these features.

TECHNICAL TOPICS

M. HOUDAILLÉ.  
SHOCK ABSORBER.  
APPLICATION FILED JAN. 17, 1912.

1,087,017.

Patented Feb. 10, 1914.

2 SHEETS—SHEET 2.

Fig. 9.

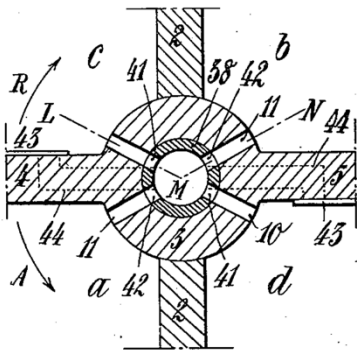
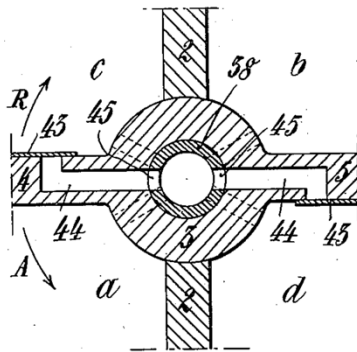

Fig. 10.



1,499,660

M. HOUDAILLE  
LIQUID SHOCK ABSORBER

Filed June 28, 1921

2 Sheets—Sheet 1

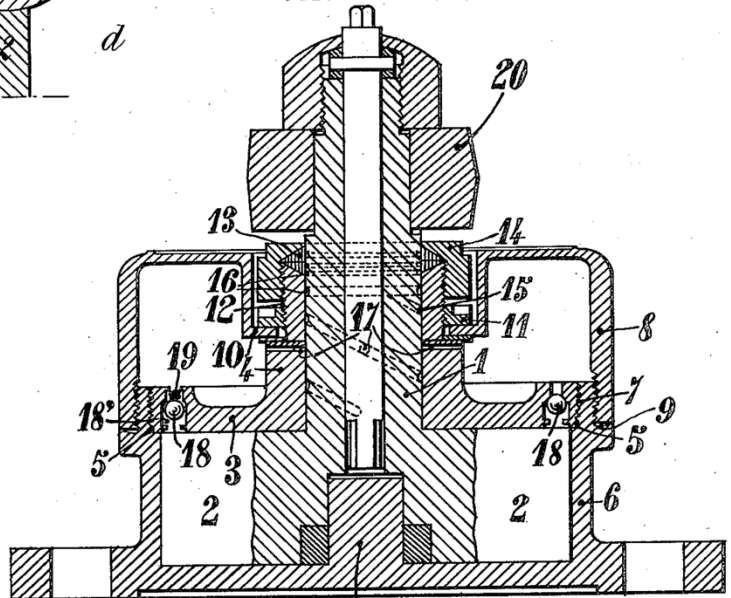

Fig. 4

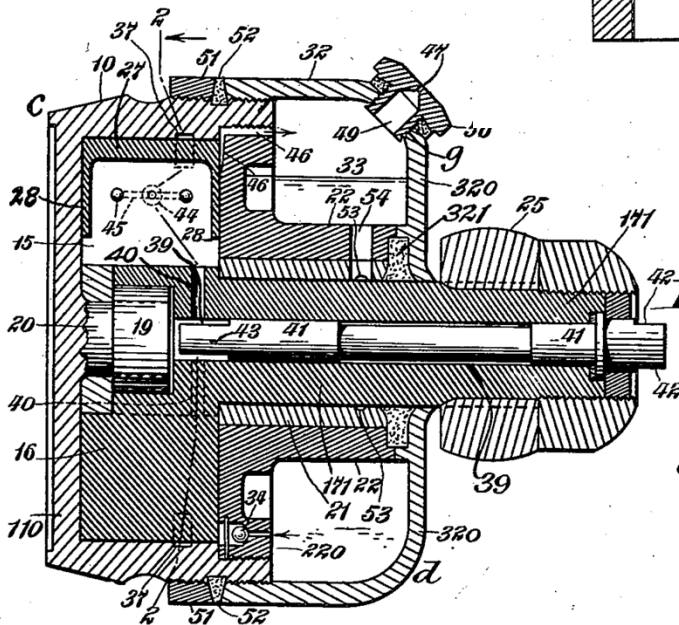

Fig. 3

Inventor  
Albert B. Shultz  
by Eyer & Popp  
Attorneys.

### Member Advertisements

Deadline for submittal - 20<sup>th</sup> of the month - Send submittals to [newsletter@ShadeTreeAs.org](mailto:newsletter@ShadeTreeAs.org)

**NEW**

**FOR SALE:** Model A Instrument Panel for use with the oval speedometer. Correct Nickle plating with a light Butler finish. \$80.00 Jim McPherson, 706-564-0120

**FOR SALE** 1930 GEORGIA license plates, Very good condition. \$100.00. Jim McPherson 706-564-0120

**FOR SALE** Original Model A Ford Distributor Housings, \$25.00 each. The reproductions are \$77.50 (plus tax, shipping and handling), and we all know how great reproduction parts are. Jim McPherson, 706-564-0120.

**FOR SALE** Steve Spencer met a man at the recent Brandon Wilde event who has a Model A horn for sale. His name is Doug Williams. He can be reached at 706-860-0055, email: [oldtimerpilot@gmail.com](mailto:oldtimerpilot@gmail.com)

### Paid Advertisements

### SHADE TREE A'S NEWSLETTER SPONSORS

*Our thanks to the following sponsors! Their generosity supports this Newsletter and the Shade Tree A's! Please remember these folks when you need a service they offer. And please, tell them you appreciate their support of our Club!*

**Bentley's**  
Antique Auto Service, Inc.

We are a Full Service Shop, specializing in Model A Fords  
We offer Award-Winning Paint and Bodywork  
Expert Service and a Complete Machine Shop

Enjoy the Drive...

**678-407-1947**



**Bert's Model "A"  
Ford Center**

2767 S. Tejon, Englewood, CO 80110  
ph# 303-293-3673 or 800-321-1931  
email address - [parts@modelastore.com](mailto:parts@modelastore.com)  
[www.modelastore.com](http://www.modelastore.com)

**We buy and sell original and reproduction Model A Ford parts!**

**BRATTON'S**  
**ANTIQUE AUTO PARTS**



800-255-1929 Phone  
 www.brattons.com  
 800-774-1930 Fax  
 1506 Back Acre Circle  
 Mount Airy, MD 21771

*Your source for Quality Model A Ford Parts since 1976*

1003 ALEXANDER DRIVE  
 AUGUSTA, GA 30909

P.O. BOX 212072  
 MARTINEZ, GA 30917

**D&M**   
**D'Antignac & Merritt Heating & Air, Inc.**  
 Turn To The Experts.

(706) 667-0196 Doug Wilson

**GERALD JONES**  
 FORD

**POWDERCOATING**  
 Professional Powdercoating Service

**JAPW Racing Inc.**

200 Rose Street  
 Martinez, GA 30907  
 info@jrpwrcing.net

Jimmy Rivers  
 706-863-1206

Mike's "A" Ford-able Parts  
**Mike Butcher** 

124 Model A Drive, Maysville, GA 30558  
 email: mike@mikes-afordable.com - www.mikes-afordable.com  
 Fax: 706 652 2492 - Phone: 706 652 3866  
 1 888 TRY MIKE (879 6453)



*Specialising in 1928 - 1931 Model A Ford Parts*

"ONE MILE AHEAD"  
*Smith and Jones*  
**ANTIQUE AUTO PARTS**  
SPECIALIZING IN MODEL A AND MODEL T PARTS  
 60 Wisconsin St. W Columbia, SC 29170

Quality Parts • Same Day Shipping  
 • Established 1972 •

Order Desk 1-800-422-1928  
 1-803-822-4141 • Fax 1-803-822-8477  
 All Major Credit Cards Accepted



**Davin E. Smith** Orders: www.snjparts.com  
 Email: snjparts@gmail.com

The World's Largest Selection of 1909-31 Ford Parts

**Snyder's**  
**ANTIQUE AUTO PARTS**

12925 Woodworth Rd. • New Springfield, OH 44443  
 Toll Free Ordering (888) 262-5712  
 or FAX (888) 262-5713  
 Order On-Line @ www.snydersantiqueauto.com



**FREE Fully Illustrated CATALOG**  
 \$10.00 outside the U.S., Canada, & Mexico

**Joseph E. Spires**  
 ATTORNEY-AT-LAW

Ward & Spires, LLC  
 445 Walker Street  
 Augusta, Georgia 30901

Phone (706) 724-2640  
 Facsimile (706) 724-2642  
 E-mail: Wardspires@aol.com