

SHADE TREE A'S



NEWSLETTER

May 2024

Volume 51

Number 5



4424 Reynolds Street
Hephzibah GA 30815-7909
Website: <http://www.ShadeTreeAs.org>



President Craig McMullin	803-341-8955 pres@ShadeTreeAs.org
Vice President Andrew Morse	706-834-2342 vp@ShadeTreeAs.org
Secretary Frank Knapp	706-736-5238 sec@ShadeTreeAs.org
Treasurer Stuart Smith	706-825-9441 treas@ShadeTreeAs.org
Tour Director Darren Riley	803-230-9510 tourdir@ShadeTreeAs.org
National Director Steve Spencer	706-294-2176 nationaldir@ShadeTreeAs.org
Board of Directors Darren Riley	803-230-9510 bod1@ShadeTreeAs.org
Board of Directors Jim McPherson	706-564-0120 bod3@ShadeTreeAs.org
Advertising Coordinator Matt Barrett	706-799-3699 ads@shadetreeas.org
Club Chaplain Ralph Neitzke	706-863-6158 chaplain@shadetreeas.org
Era Fashions Anne Neely-Beck	478-945-3736 erafashions@ShadeTreeAs.org
Librarian Pat Riley	803-417-6583 librarian@shadetreeas.org
Membership Coordinator Frank Knapp	706-736-5238 membership@ShadeTreeAs.org
Newsletter Editor Robbie Jones	706-860-2758 newsletter@ShadeTreeAs.org
Photographer Sheila McPherson	706-592-4835 photographer@ShadeTreeAs.org
Webmaster Dan Perla	706-373-5730 webmaster@ShadeTreeAs.org



CONTENTS

Columns	
Off the Running Board	3
Meeting Minutes	3
Board of Directors Meeting Minutes	5
Club Calendar	6
Announcements	
Shade Tree A's Member News	7
Refreshment Schedule	7
Birthdays	7
Other Sundry Announcements	8
Recent Events	
A Model A Picnic	19
Model A Era Fashion and Style	20
The Shade Tree A's - Thirty Years Ago	24
Technical Topics	25
Advertisements	26

On the Front Cover

May through October is typically considered Wedding Season, but Robbie Jones's daughter, Keri, wanted a December wedding. She also insisted on riding away in Robbie and Leta's 1931 Slant Window Deluxe Fordor. Photo by Michael David Productions, used with permission.

On the Back Cover

Robbie and Leta's Model A is all decorated and ready to drive the bride and groom away. The car is considered the family wedding car; Robbie and Leta rode away from their wedding many years ago in the same car. The car has also been used for weddings of other family members and close friends of the family. Photo by Robbie Jones.

SHADE TREE A'S MODEL A CLUB

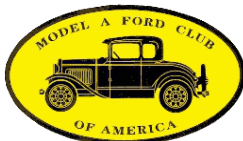

The Shade Tree A's Model A Club is a non-profit organization dedicated to the preservation and the restoration of the Model A Ford automobile. Shade Tree A's annual dues are only \$25. Members are urged to join the Model A Ford Club of America (www.mafca.com) and the Model A Restorer's Club (www.model-a-ford.org) to enjoy the benefits of these national organizations including their respective magazines: *The Restorer* (MAFCA) and *Model A News* (MARC). The Shade Tree A's club is also a member of MAFFI, the Model "A" Ford Foundation, Inc.



CONTACT INFORMATION

4424 Reynolds Street
 Hephzibah GA 30815-7909
 Website: <http://www.ShadeTreeAs.org>

ABOUT THIS NEWSLETTER

© 2024 Shade Tree A's, except as noted.
 Please contact Robbie Jones at Newsletter@ShadeTreeAs.org concerning reprinting of articles, illustrations, or photos.

OFF THE RUNNING BOARD

Craig McMullin - President

If you like to tour, our new Tour Director, Darren Riley, is the guy to see. Already he has a full slate of tours lined-up for the month of May. To start with, The Johnston Peach Blossom Festival Parade on Saturday, May 4th, the Stuckey's Pecan Candy Factory tour to Wrens, GA on Friday, May 10th, the tour to Magnolia Ridge Antique Flee Market and Tractor Show in Ridge Spring, SC on Saturday, May 18th, and the Aiken Memorial Day Parade on Saturday, May 25th. Darren is trying to make up for lost time with a bang and will do an excellent job as the STA Tour Director. I look forward to working with Darren on his tour schedule in 2024 and beyond. Thank You, Darren.

Don't forget the "Pizza Lunch Bunch" every Wednesday morning at 11AM or a little later. Our group has grown from 5-6 members to now 8-10 depending on individual commitments. Discussions revolve around solving world problems, senior citizen medical procedures, STA upcoming events, and yes even Model A Ford technical repair issues including tried and proven corrective actions. We meet at Cicis Pizza at 4025 Wheeler Road. For about \$12.46, you can get all you can eat salad bar, pasta bar, pizza bar and even a few deserts and a drink, all included. Cicis is one of our many newsletter sponsors and they take good care of us every Wednesday. Come join us!!

Ahooga,

Craig McMullin - President

MEETING MINUTES

April 8, 2024

Richard's Garage

Respectfully submitted: Frank Knapp - Secretary

The monthly meeting of The Shade Tree A's was held April 8, 2024 in the clubhouse meeting room at Richard Dunevent's garage. Once again, in the absence of our President, V.P. Andrew Morse called the meeting to order at 6:53 PM welcoming all twenty-two members present. Members were asked to sign-up for May refreshments, however no one volunteered. We did however gain a new member. Donna Weaver, Charlie Weaver Jr.'s sister, became our newest member. Welcome Donna! Only one member contributed to our Name Tag Penalty Cup.

Due to the absence of both Matt Barrett and John Neumar, no "Joke of the Month" was offered. The only member present with an April Birthday was Kathy Poole. Happy Birthday Kathy!

Don Gordon, Misty Hooker's brother, informed the group she continues to improve and is confident there will be a good outcome. After the meeting adjourned, it was learned Debra Weaver is currently hospitalized suffering from a serious lung condition. Prayers for her quick recovery!

Vice President: Andrew Morse announced our technical program will be Part Three of "The Model A Transmission". Also, members were urged to consider presenting a Technical Program in the future.

MONTHLY MEETING TIME & LOCATION
Meetings are held on the second Monday of each month at Richard Dunevent's garage, 4338 Owens Road, Evans, Georgia. Meetings begin at 7:00 PM and are followed by refreshments.

MEETING MINUTES

Continued

Treasurer: Stuart Smith reported \$973.51 for various expenditures were paid-out with only \$126.00 in deposits made. In order to keep our treasury solvent, the Certificate of Deposit which recently matured will not be reinvested. Instead, the proceeds will be added to our working account to cover future expenses.

A motion was made and seconded to approve the Treasurer's Report and the March Meeting Minutes as published in *The Newsletter*. That motion passed by unanimous vote.

National Director: Steve Spencer reported he continues to submit STA Activities to *The Restorer* and *Model A News*, unfortunately they have occasionally been misrouted when delivered to these publications. That problem has been resolved and should not be an issue in the future.

Newsletter Editor: Robbie Jones stated any photographs of minor children submitted for inclusion in *The Newsletter* will now require permission from parents. He asks anyone offering these pictures send along the appropriate permission info.

Tour Director: Darren Riley invited anyone wanting to caravan to The Old 96 Swap Meet Saturday morning April 20th meet him either at Pollard's Corner at 9:00 AM or, if it's more convenient, across the dam at the intersection of GA. Hwy. 221 and SC Hwy. 28 no later than 9:15 AM.

Show & Tell: Kenny Adkins announced he has found a shop that can remedy the problem with his '31 Pickup's radiator. Problem is, Kenny's repair project is tenth on the list to be done. Darren Riley brought along the damaged transmission housing found on Kathy Poole's coupe. According to Darren, repairs are moving along well.

Steve Spencer advised the group he is planning a trip to Kentucky to visit his sister who also inherited one of their dad's A's. Hopefully he can get it back on the road during his stay.

Old Business: Members were asked for comments on several recent events. Included were our Saturday Tech Session, The St. Patrick's Day Parade and The Palmetto A's Annual Picnic in Lexington, S.C. Several STA members attended and all made positive remarks.

New Business: The following tours and events were brought to the attention of members. The Johnston Peach Parade May 4th, The Old 96 Swap Meet April 20th, our upcoming tour to Stuckey's Pecan and Candy Factory in Wrens, Ga. May 10th, The Magnolia Ridge Antique Flee Market May 18th, and the MARC National Meet July 15th-18th. Also, mention was made of a visit to Augusta by the Queen City Model A Club while touring to The Florida Keys. STA members are invited to meet for dinner with that group on Saturday June 1st.

Technical Program: Dan Perla concluded his series on The Model A Transmission with the third and last episode, "The Model A Transmission-Assembly". Everyone agreed these excellent videos produced by George Bell were very interesting and informative! Thanks again Dan for THREE excellent programs.

MEETING MINUTES

Continued

There being no further business, the meeting was adjourned at 7:50 PM after which members enjoyed refreshments including a generous serving of McDonald's Chicken McNuggets, delicious cake, ice cream and soft drinks provided by Steve Spencer, Paula Mason and Richard Walker.

Month by month dates for activities such as technical seminars and official club tours were planned for the remainder of 2024.

All items mentioned above will be presented to the entire membership at our May meeting for approval and any other ideas and/or suggestions will be welcomed from our members.

There being no further business, the meeting was adjourned at 8:15 P.M.

Your Board of Directors has planned a fun-filled variety of tours and activities and we urge all of our members to participate!

BOARD of DIRECTORS MEETING MINUTES

April 22, 2024

Richard's Garage

Respectfully submitted: Frank Knapp – Secretary

The Shade Tree A's Board of Directors met April 22, 2024 at our club meeting room at Richard Dunevent's garage. Board members present included President Craig McMullin, Vice President Andrew Morse, Treasurer Stuart Smith, Secretary Frank Knapp, National Director Steve Spencer, Jim McPherson and Darren Riley. Other STA members Larry DuVall and Sheila McPherson were also in attendance.

President Craig brought the meeting to order promptly at 6:30 PM with three main topics on the agenda. Those included The Budget, our Certificate of Deposit and Scheduling Club Activities through December 2024.

The current status of our treasury, including both projected income and expenses for 2024, was discussed at length. After analyzing income and expenditures from 2023 and 2024, a complete and detailed budget for the year 2025 was also created. The Board voted to renew the Certificate of Deposit that recently matured.

Johnston Peach Festival Parade

Saturday, May 4th

Parade starts at 10:30 AM

Parade lineup at 9:30 AM

Arrive at NAPA in Johnston, SC at 8:45 AM for breakfast biscuits and coffee and juice. Restrooms are available and a tour of the facility as time permits.

Rachel Williams will be our host who manages the NAPA Operation and is the daughter and niece of this family owned business enterprise.

If you are planning on attending, please let Darren Riley know, so we can provide an estimated headcount for the kind folks at NAPA.

CLUB CALENDAR

Shade Tree A's Events

May

- 4 Johnston Peach Festival Parade, see announcement on previous page
- 13 Shade Tree A's Meeting, 7:00 PM, Richard's garage (Technical Program: *The Model A Front Spring* - presented by Darren Riley)
- 18 Grandpa's (Jim Dover) Low Country Boil, 11:00AM - 5:00 PM, 596 Springhaven Drive, North Augusta, SC

June

- 1 Queen City Model A Club (Charlotte) visit to Augusta (see announcement on page 9)
- 10 Shade Tree A's Meeting, 7:00 PM, Richard's garage (Technical Program: *TBA*)
- 22 Shade Tree A's Technical Session, Richard's garage, 9:00 AM – noon, rain date June 29

July

- 8 Shade Tree A's Meeting, 7:00 PM, Richard's garage (Technical Program: *TBA*)

August

- 16-17 Shade Tree A's Swap Meet, Thomson, GA

Every Wednesday at 11:00

Join the Shade Tree A's for lunch at Cicis Pizza on Wheeler Road

TBA - To Be Announced

Other Events of Interest

May

- 10-11 Model A & T Swap Meet hosted by the Shenandoah Valley Racket "T"ers, Luray, VA, contact Dennis Fleming at 540-860-1384, dennis@fairviewnet.com
- 18 Magnolia Ridge Antique Flea Market, Ridge Spring, SC
- 27 17th Annual Benson Classic Car Show, 10:00 AM to 2:00 PM, Benson Fiat-Alfa Romeo Studio, 500A West Wade Hampton Boulevard, Greer, SC (contact Jean Gilstrap at gilstrapacanews@gmail.com)

June

- 14-15 Palmetto A's Swap Meet, Columbia, SC, contact John Cockerill at 803-446-3837, johntwilac@yahoo.com
- 15 Journey Community Church Cruise-In, 10:00 AM – noon, 4798 Hardy McManus Road, Evans, GA

July

- 15-18 MARC National Meet, Asheville, NC, additional details provided later in the *Newsletter*

October

- 8-11 AACA Eastern Fall National Meet, Hershey, PA
- 23-26 AACA Southeastern Fall National Meet, Huntsville, AL

ANNOUNCEMENTS

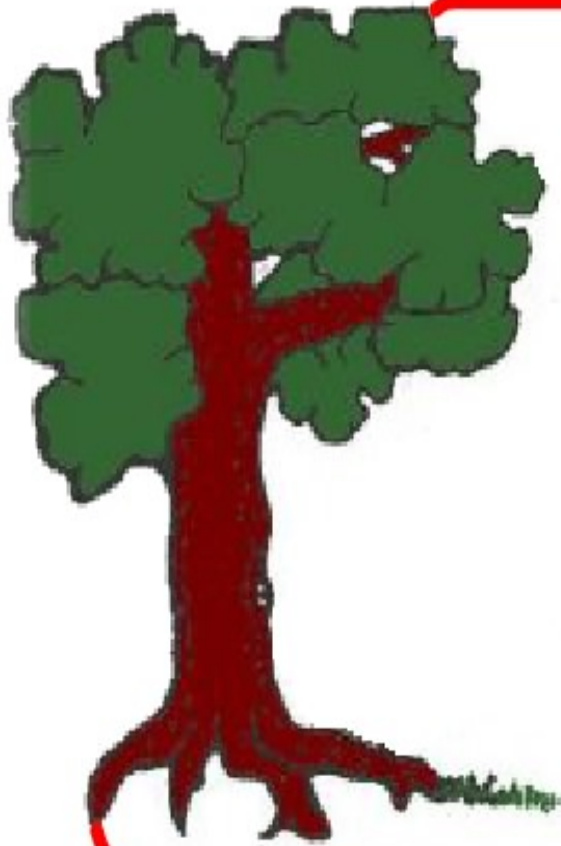

Shade Tree A's Member News

- Please continue to keep the following Shade Tree A's members in your thoughts and prayers:
 - Janet Neumar being treated for lung cancer.
 - Misty Hooker has completed chemotherapy treatments with no evidence of her cancer spreading. Prayers for her continued progress are appreciated.
 - Abbie Prince and Eric Shogren recovering from recent surgeries.
 - Debra Weaver is recovering from a serious lung condition
- Longtime friend of the Shade Tree A's Ralph Raub of the Old 96 District Model A Club is battling a serious illness. He and Madge will be moving back to Ohio soon.

Send items for Shade Tree A's Member News to:
newsletter@ShadeTreeAs.org



Refreshment Schedule

May

Jim & Sheila McPherson, any volunteers to help, call Jim or Sheila

June

Darren & Pat Riley, Kenny Adkins, Darrell & Syble Henderson

July

Robert & Sandra Reis, Don Gordon, Misty Hooker

The first person listed is the primary coordinator for the month



May Birthdays

2	Donna Young	5	Montie Knapp
8	Lois Melchiors	10	Kent Carruthers
10	John Neumar	11	Mike Gordon
13	Josh Dover	16	Kathy Poole
18	Dotti Shogren	19	Rebecca Dover
19	Brenda Prince	20	Gerald Melchiors
21	Billy Garland	24	Linda Krosting
27	Misty Hooker	27	Debra Weaver
28	Ben Deitz	28	Don Gordon
28	Betty Wade		

ANNOUNCEMENTS



Shade Tree A's Swap Meet

sponsored by the

Shade Tree A's Model A Ford Club

1818 Augusta Highway, Thomson, Georgia 30824

Friday, August 16 and Saturday, August 17, 2024, 8:00 AM until 2:00 PM

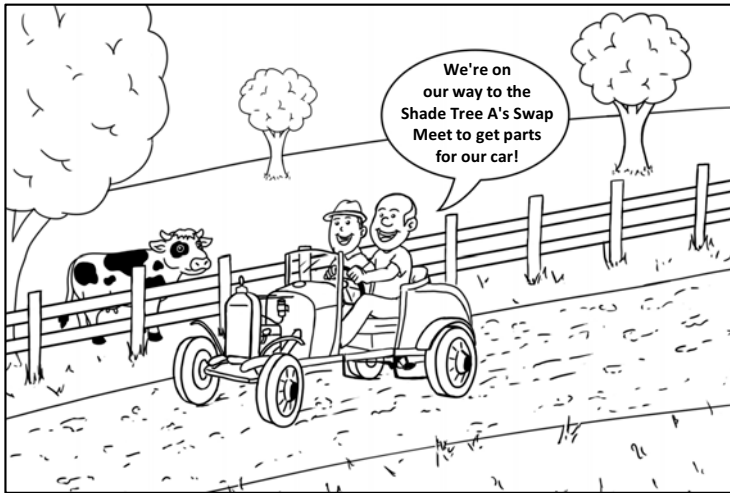

There is no Parking, Admission or Vendor fee for this event. Come enjoy your day with fellow Model A enthusiasts. This year we are sponsoring a special workshop on Model A distributors. See details below. Lunch available.

For more information, contact:

Andrew Morse

706-834-2342

4morses@comcast.net

Jim McPherson

706-564-0120

Distributor Diagnostics and Rebuilding Workshop

SATURDAY, 10:00 AM – 12:00 Noon

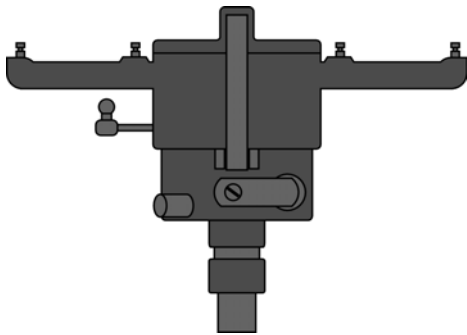

The Shade Tree A's are proud to present a hands on workshop on the Model A distributor. Have your distributor issues professionally evaluated, or get help rebuilding your distributor. Eric Shogren, owner of Guben's Garage, a Model A repair facility, will be available to evaluate your distributor or assist in rebuilding your distributor. Bring your distributor, and the new parts to rebuild it, and Eric will have the tools available to rebuild your distributor.

Smith and Jones Antique Auto Parts will be attending our Swap Meet. Contact Davin Smith with your parts order for delivery to the Swap Meet and save on shipping.

Phone: 803-822-4141, 800-422-1928; e-mail: snjparts@gmail.com



For vendor registration, please contact Andrew Morse or Jim McPherson

ANNOUNCEMENTS

Shade Tree A's Tour to Stuckey's in Wrens, GA

The tour to Stuckey's is on AGAIN!! Come join us on Friday, May 10, 2024, to see first-hand how one of your favorite candies are made. We will travel by Model A Ford of course to Wrens, GA to the home of the Stuckey Candy Factory and Retail Store. We will leave from the Burger King parking lot on the corner of Barton Chapel and Dean's Bridge Road (2688 Deans Bridge Road) at 10:00 AM and follow Highway 1 to Wrens GA (26 miles). We will get a factory tour and discount on their goods for sale. Stephanie Stuckey (Chairperson of the Company), whose grandfather founded Stuckey's Candies in 1937 while driving a Model A Ford, will be our host. After the Stuckey's factory tour and before heading back home we will have lunch (on your own) at the famous Peggy's Restaurant in Wrens.

Please contact Darren Riley (803-230-9510) if you are going so we can plan for seating at Peggy's.

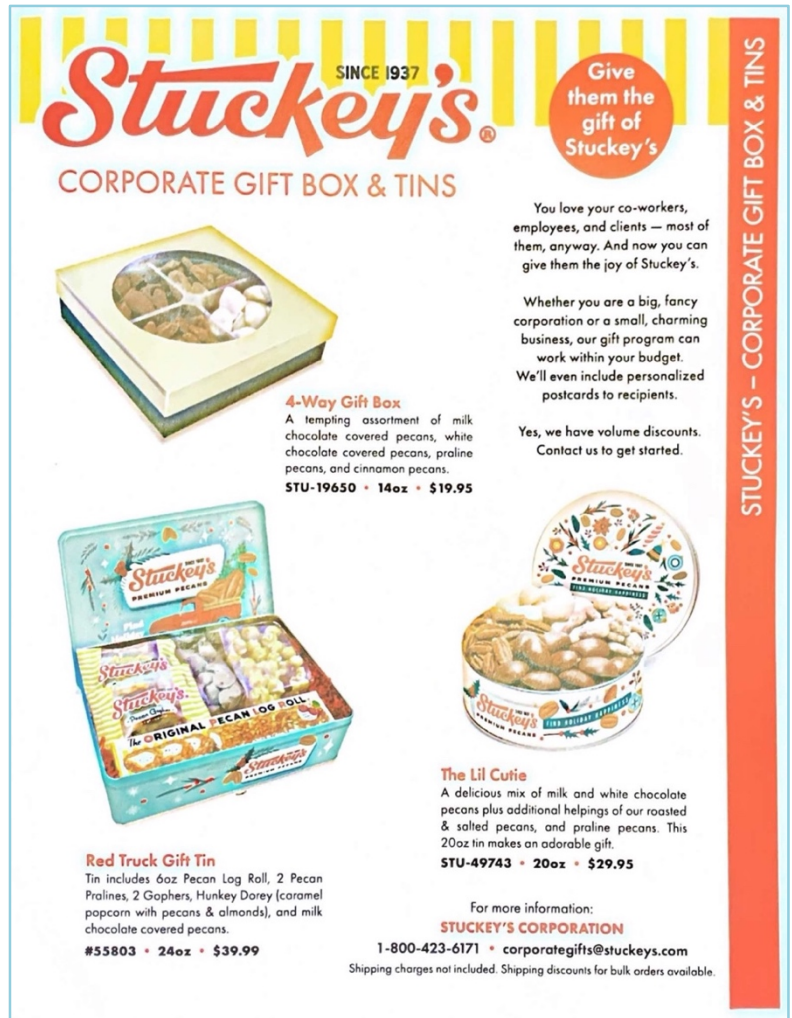

Stuckey's SINCE 1937
CORPORATE GIFT BOX & TINS

Give them the gift of Stuckey's

You love your co-workers, employees, and clients — most of them, anyway. And now you can give them the joy of Stuckey's.

Whether you are a big, fancy corporation or a small, charming business, our gift program can work within your budget. We'll even include personalized postcards to recipients.

Yes, we have volume discounts. Contact us to get started.

4-Way Gift Box
A tempting assortment of milk chocolate covered pecans, white chocolate covered pecans, praline pecans, and cinnamon pecans.
STU-19650 • 14oz • \$19.95

Red Truck Gift Tin
Tin includes 6oz Pecan Log Roll, 2 Pecan Pralines, 2 Gophers, Hunkey Dorey (caramel popcorn with pecans & almonds), and milk chocolate covered pecans.
#55803 • 24oz • \$39.99

The Lil Cutie
A delicious mix of milk and white chocolate pecans plus additional helpings of our roasted & salted pecans, and praline pecans. This 20oz tin makes an adorable gift.
STU-49743 • 20oz • \$29.95

For more information:
STUCKEY'S CORPORATION
1-800-423-6171 • corporategifts@stuckeys.com
Shipping charges not included. Shipping discounts for bulk orders available.

STUCKEY'S - CORPORATE GIFT BOX & TINS

Queen City Model A Club Tour to Augusta, GA

On Saturday June 1st we will meet with the Queen City Model A Club from Charlotte, North Carolina in the big room upstairs at Sconyers Bar-B-Que at 6:00 PM. The Queen City club is touring to Augusta and some are even continuing on to Key West! This should be a lot of fun meeting new friends, hearing about their trip and enjoying some great BBQ. Hope to see you all there.



ANNOUNCEMENTS

Join Us on a Tour to Asheville, NC and the Model A Restorer's Club 2024 National Meet

The Shade Tree A's are planning a tour to Asheville, NC to attend the MARC National Meet July 15-18. Will you join us? This is your opportunity to attend and participate in a national Model A event. I would expect 300 or more Model A's to be there, plus a variety of seminars, a swap meet, and era fashion events (meet schedule not yet available). There will be a Welcome Party, an Era Fashion Show/Ice Cream Social, a Grand Tour on Thursday, and an Awards Banquet. You can choose which events you want to participate in. If you cannot attend the entire event, I would encourage you to look at the meet schedule and attend one or more days having events that interest you. Asheville is about 170 miles, and we can drive Highway 25 all the way. We have toured to Asheville and the surrounding area many times in the past. Some will drive their Model A, some will trailer their Model A (special trailer parking will be available), and some will drive their modern car. Robbie has posted the hotel information in the *Newsletter*. The host hotel was full in three days. A number of Shade Tree A's members have already indicated they will attend. Will you join us?

Lodging at the National Meet:

Many Shade Tree A's members are staying at the Holiday Inn Express, Asheville SW, Outlet Center, 12 Rocky Ridge Road. The local phone number is 828-665-6519. Use the code "The Nashville A's" to get the meet rate. The phone number listed in the Meet Announcement is for the National Reservation Line.

Additional information is provided on the following pages. Registration forms are included in the January/February 2024 issue of the *Model A News* magazine.



Photo by Robbie Jones

ANNOUNCEMENTS

ASHEVILLE, N.C. MARC NATIONAL MEET JULY 15TH-18TH. 2024

BOOKING IS NOW OPEN AT THE HOST HOTEL!



SALE OUT

CROWNE PLAZA RESORT ASHEVILLE
1 RESORT DRIVE, ASHEVILLE, NORTH CAROLINA 28806
ROOMS ARE \$169.00* PER NIGHT. CALL: 1-844-330-0296
GROUP CODE: NASHVILLE A'S 2024 OR ON LINE AT:
WWW.ASHEVILLECP.COM 24 HOURS AVAILABILITY (ENTER DATES OF STAY)
ENTER GROUP CODE: MDA



“DON'T BE BASHFUL... MEET US IN ASHEVILLE”

**FOR MORE INFORMATION PLEASE CONTACT YOUR MEET CHAIRMAN
PAUL GANNINGER 314-852-5591 OR EMAIL MARCMEET2024@GMAIL.COM**



*PLUS TAXES, ALL ROOMS AT HOST HOTEL WILL REQUIRE A 1 NIGHT DEPOSIT PER ROOM & NAMES FOR EACH ROOM BOOKED. MAXIMUM OF 2 ROOMS.
HOSTED BY THE NASHVILLE A'S REGION

ANNOUNCEMENTS

ASHEVILLE 2024 MARC NATIONAL MEET

JULY 15TH-18TH 2024

BOOKING IS NOW OPEN

AT THESE ADDITIONAL HOTELS!

HOSTED BY THE NASHVILLE A'S REGION



COUNTRY INN & SUITES ASHEVILLE RIVER ARTS DISTRICT
22 WESTGATE PARKWAY, ASHEVILLE, NC
TEL:1-828-772-3188
\$109.00 PER NIGHT* INCLUDING BREAKFAST
CODE:NASHVILLE A'S
.03 MILES FROM HOST



HOLIDAY INN ASHEVILLE-BILTMORE WEST
435 SMOKEY PARK HIGHWAY, ASHEVILLE, NC 28806
TEL:(828)665-2161
\$105.00 PER NIGHT*
CODE:THE NASHVILLE A'S
6.1 MILES TO HOST



HOLIDAY INN & EXPRESS, ASHEVILLE SW - OUTLET CTR
12 ROCKY RIDGE ROAD, ASHEVILLE, NC 28806
TEL:1-888-465-4329
\$108.00 PER NIGHT* INCLUDING BREAKFAST
CODE: THE NASHVILLE A'S
5 MILES TO HOST



COMFORT SUITES OUTLET CENTER
890 BREVARD RD., ASHEVILLE, NC, 28806
TEL: (828) 665-4000
\$85.00 PER NIGHT* INCLUDING BREAKFAST
CODE: THE NASHVILLE A'S OA55F3
6.5 MILES TO HOST



CAMPING: THE PARKWAY HAS FOUR CAMPING AREAS IN THE ASHEVILLE AREA, OPEN APRIL OR MAY THROUGH OCTOBER. CAMPING IS \$20/NIGHT FOR ALL CAMPGROUNDS, FIRST-COME FIRST-SERVE. ADVANCE RESERVATIONS ACCEPTED AT ALL CAMPGROUNDS EXCEPT CRABTREE FALLS. CAMPING ALONG THE PARKWAY IS PERMITTED ONLY IN DESIGNATED CAMPGROUNDS. CALL 828-765-6082 FOR MORE INFORMATION

“DON'T BE BASHFUL, MEET US IN ASHEVILLE”

FOR MORE INFORMATION PLEASE CONTACT YOUR MEET CHAIRMAN

PAUL GANNINGER 314-852-5591 OR EMAIL MARCMEET2024@GMAIL.COM

*PLUS TAXES, ALL ROOMS AT HOST HOTEL WILL REQUIRE A 1 NIGHT DEPOSIT PER ROOM & NAMES FOR EACH ROOM BOOKED. MAXIMUM OF 2 ROOMS.

ANNOUNCEMENTS

ASHEVILLE, N.C. MARC NATIONAL MEET JULY 15TH-18TH. 2024

THE GRAND TOUR THURSDAY JULY 18, 2024. TO THE "BLUE RIDGE PARKWAY"

THE BLUE RIDGE PARKWAY NEAR ASHEVILLE IS ONE OF THE MOST BEAUTIFUL DRIVES IN AMERICA

COUNTLESS PEOPLE FLOCK TO THE MAJESTIC MOUNTAINS OF NORTH CAROLINA THROUGHOUT THE YEAR TO ESCAPE TO ITS PEACEFUL TRANQUILITY AND BREATHTAKING BEAUTY. ONE OF THE MOST ICONIC ATTRACTIONS OF THIS AREA IS THE STUNNING BLUE RIDGE PARKWAY, A WINDING ROUTE THAT FEATURES JAW-DROPPING VIEWS AND OUTSTANDING OUTDOOR RECREATION. FILLED WITH THRIVING PLANTS AND WILDLIFE, THIS IS ONE OF THE BEST PLACES IN THE STATE TO VISIT FOR A RELAXING TRIP IN THE CRISP, MOUNTAIN AIR. "AMERICA'S FAVORITE DRIVE,"

WHERE DOES THE BLUE RIDGE PARKWAY START?

THE BLUE RIDGE PARKWAY STARTS IN SKYLINE DRIVE OF SHENANDOAH NATIONAL PARK IN VIRGINIA AND STRETCHES ALL THE WAY TO THE GREAT SMOKY MOUNTAINS NATIONAL PARK IN CHEROKEE, NORTH CAROLINA. THERE ARE NUMEROUS BLUE RIDGE PARKWAY ACCESS POINTS SCATTERED ALONG THIS RANGE. EACH ACCESS POINT HAS A SYMBOL THAT INDICATES IF IT IS WHEELCHAIR ACCESSIBLE AND IF IT CONTAINS A PICNIC AREA. SOME INCLUDE VISITOR CENTERS, RESTROOMS, EXHIBITS, AND MORE.

WHAT ARE SOME THINGS TO DO ALONG THE BLUE RIDGE PARKWAY?

ALONG THE BLUE RIDGE PARKWAY HIKING IS AN OPTION IN MANY SPOTS, PROVIDING AMAZING VIEWS OF MOUNTAINS AND WATERFALLS ALONG EACH ROUTE. YOU CAN ALSO CHOOSE TO SIMPLY DRIVE ALONG THE BLUE RIDGE PARKWAY NEAR ASHEVILLE, ADMIRING THE ABUNDANCE OF SCENIC SIGHTS ALONG THE WAY. THERE ARE MANY OVERLOOK AREAS WHERE YOU CAN STOP TO TAKE PICTURES TO COMMEMORATE YOUR TRIP TO THIS GORGEOUS REGION. PICNICKING, BIKING, AND FISHING ARE PERMITTED IN CERTAIN AREAS HERE AS WELL. BE SURE TO CHECK THE ROAD CONDITIONS BEFORE YOU EMBARK ON YOUR DRIVE AND STAY VIGILANT OF SPEED LIMIT SIGNS.



PLEASE NOTE: THE PARKWAY IS A NATIONAL PARK AND THERE ARE NO FEES OR STICKERS NEEDED TO TRAVEL IT.

**"DON'T BE BASHFUL...
MEET US IN ASHEVILLE"**

FOR MORE INFORMATION PLEASE CONTACT YOUR MEET CHAIRMAN
PAUL GANNINGER 314-852-5591 OR EMAIL MARCMEET2024@GMAIL.COM

HOSTED BY THE NASHVILLE A'S REGION



ANNOUNCEMENTS

19th Annual

ALL Model A & Model T SWAP MEET

at

**Smith & Jones Antique Auto Parts
60 Wisconsin St. West Columbia, SC**

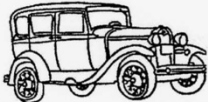

sponsored by

Palmetto A's of South Carolina

Friday, June 14, 2024 8am to 5pm

Saturday, June 15, 2024 8am to 3pm

**Vendor Space: Early registration: \$15/one day \$25/two days
or \$20/\$30 at the gate**

Car Corral: \$10 for two days

Palmetto A Members - Free Vendor Space

\$2 Door Prize Tickets Food Concession 50/50

**Contact: Dick Fraser at 803-622-7582 or
dickfraser@earthlink.net**

Vendor Sign Up Form

Name: _____

Address _____

City _____ State _____ Zip _____

Telephone _____ email _____

Will you be arriving and setting up on Thursday, June 13? _____

Are you primarily a Model A or Model T Vendor? _____

Please mail this form along with a check or money order made payable to:

Palmetto A's of SC--- 113 Ian Dr. Leesville, SC 29070

By participation in this event and signing this form I/we agree to hold harmless
The Palmetto A's of SC Model A Club, Smith & Jones Antique Auto Parts and any of the
members or agents thereof, in the event of accident or injury to any participant, person or group.

Signature _____ Date _____

ANNOUNCEMENTS

JOURNEY COMMUNITY CHURCH'S ANNUAL



CRUISE-IN

SATURDAY, JUNE 15TH

10:00AM-12:00PM

ON THE EVANS CAMPUS
4798 HARDY MCMANUS RD EVANS, GA

FREE FOOD
ALL BIKES, TRUCKS, & CARS WELCOME

ANNOUNCEMENTS



**Model A Ford Foundation Inc.
MAFFI Minute, April 2024**



Now you can shop from the comfort of your home for wearing apparel and home décor specific to YOUR Model A and help the museum out in the process!

MAFFI has paired with a company that provides a variety of Model A products that can be customized, to your Model A/year! Or if you prefer, the merchandise can have the MAFFI logo on it. You can buy t-shirts, polo shirts, sweatshirts, hoodies, aprons, and hats to wear.

Or, if your home or shop need some Model A décor you can buy wall art or a clock and more . . .

The company that we partnered with takes the orders on-line with credit cards and ships your custom order to your home. MAFFI gets 10% of the proceeds from each sale, so you are helping the museum every time you shop and getting great products.

It's easy: go to the MAFFI.org website, click on Store and you will be rerouted to the ModelAtshirt store. **It is important to shop by going through the MAFFI website though.** It's the only way our partner knows to give us 10% of the sale. If you go directly to the ModelAtshirt website, staff don't know you are a MAFFI customer and you pay the same price, but the museum doesn't get anything.

We know not everyone can get to Hickory Corners, MI to buy Model A merchandise; now you can shop Model A items 24/7 year around! And with Mother's and Father's Day around the corner, we've just made shopping a bit easier for the Model A enthusiasts in your life.

The accompanying pictures are some of my purchases; I guess you know what I drive for a Model A!

Happy Motoring,
Cindy Ellenbecker, Secretary
Model A Ford Foundation Inc. Trustee



ANNOUNCEMENTS

Model A Ford  *Club of America*
250 So. Cypress La Habra, California 90631-5586
562-697-2712

March 2024 President's Flying Quail Message

For those that subscribe to the *Flying Quail* newsletter, I'm sure you've noticed the revised look and enhanced content. The new *Flying Quail* appearance is vibrant and refreshing. I would like to thank Will Langford, Chapter Coordinator Director and Gary Price, Secretary especially for their efforts to renew and revitalize the publication. I would also like to thank all those that contribute articles and material to be include in the newsletter. Keep those articles coming. If you do not subscribe, you should check it out. I think you will find it very informative and interesting.

A couple of months into the new year and I hope you haven't broken all your new year resolutions. I hope you are still getting that "little bit of exercise" each day, eating wiser and healthier and haven't slipped back into that bad habit you swore to yourself to stop. Staying true to the course on our new years' resolutions, as my father once said after trying to hit a golf ball for the first time in his fifties: "It's harder than it looks". After a slow year in 2023, for Elaine and I at least, and driving our Model A only a little more the 5,000 miles my resolution is to drive my Model A weekly, weather permitting. Not to necessarily make it my daily driver but to get it out on a regular basis. So far, so good. Good 'ol south Texas weather makes that possible. Maybe not in your area, but good look getting you Model A out and about on a more regular basis in 2024.

Now is the time for you to decide if you are interested in participating in MAFCA's leadership as a National Director. Information is available on the MAFCA website at: <https://www.mafca.com/elections.html>. Additionally, each Director is available to answer your questions and help steer you in the right direction to run for office.

Our 2024 MAFCA national convention, Southwest "A"ventures", is scheduled for June 23 – 29 and is being hosted by the Southeast Model A's. They have planned a great list of activities and are working diligently to put together a great outing. Check their webpage: <https://www.southwestaventures.com/> for information on registration, including the registration forms, convention clothing items, raffle items and access to purchasing raffle tickets. Sounds too good to miss so start your planning now!

In prior years MAFCA has clearly supported the concept that youth are essential to the Model A hobby's future and chapters are the means to introduce youth to the hobby. Establishing club activities that invite youth participation is a fundamental key to turning our youth into lifelong hobbyists. May of each year has been designated as Model A Youth Month. Now is the time for chapters to complete their planning and beginning to publicize their event. I look forward to reading about the many different ways our chapters are involving our youth in the hobby.

"See you down the road!" Robert Bullard

ANNOUNCEMENTS

Model A's in the News

Rational Model A

Story by Robbie Jones

Photos from Old Cars Magazine

The April 15, 2024 issue of *Old Cars* magazine (oldcarsweekly.com) included an interesting article on a unique Model A pickup truck based on a 1930 Coupe owned by Fred Wicker. Fred is quoted in the article stating "It was turned into a ration truck in 1943 or '44". He further states "The fellow had a young family and he didn't go into the service. You could get four gallons of gas a week with a car, you could get eight gallons of gas a week if you had a truck." Wicker believes the conversion used a kit based on the hardware evident on the Coupe. The article states that Sears Roebuck, Montgomery Ward, Pep Boys, Western Auto made conversion kits for Model A Coupes. The article covers three pages and includes several pictures. Be sure to check out the article if you have or can find a copy.

Setting aside for a moment the fact that the box is made of wood, the coupe's rear side-window gives the ration truck a look not unlike that of an Australian ute.



RECENT EVENTS

A Model A Picnic

Story by Jim McPherson, Photos by Sheila McPherson



The Palmetto A's of Columbia, SC held their 29th annual picnic Saturday April 4th at St. James Lutheran Church in Lexington, SC. Bob and Sandy Reis drove their 1929 Model A Woody Panel Truck and Jim and Sheila McPherson went modern. About 15 Model A's and about 40 Model A'ers braved the windy but warm weather to attend. At noon, a buffet lunch greeted the crowd. A 50/50 drawing and a silent auction rounded out the day's activity.



MODEL A ERA FASHION AND STYLE

The following article is provided by MAFCA

Whoopee Trousers: Young Men's Style or Mere Catchphrase?

By Laurie Elliott, Santa Clara Valley Chapter

The ad in a M.W. Savage Co., Spring/Summer, 1931 catalog really caught my eye as both the header at the top of the page and the drawing of the center model who was wearing rather wild pants held a banner that used the word "Whoopee." A song began playing inside my head:

"Another bride, Another groom, Another sunny honeymoon, Another season, Another reason, For making whoopee."

The song, usually referred to as "Makin' Whoopee!" is a jazz/blues song popularized by Eddie Cantor, published and released in November 1928 and appeared in the musical play "Whoopee!" that same year. A movie version of the play was made in 1930. The song has been recorded by numerous artists from Rudy Vallee to Cyndi Lauper, and appears in many movies and TV shows, including Sesame Street where Cookie Monster croons his version, "Eating Cookie." Clearly this song was popular, but I doubt the suggestive "whoopee" in the song means the same thing as the "whoopee" in the ad, which is defined by Webster's as a cry of joy or excitement. Perhaps the ambiguous meaning was part of the appeal by savvy copywriters.

The "Whoopee Style" Ad

By today's standards, these trousers look pretty tame, but in the Model A years of 1928-1931, they were downright imaginative. The ads were mostly aimed at young collegiate men or high schoolers with waist sizes 28" through 36".

The variety of trouser features are shown in the page at left. Some slacks had extended waistbands which may or may not have been shaped, and many had the "new" taller waistbands of 2-3". The text reads, "No belt, no suspenders needed." An adjustable strap and buckle in the back allowed for easy fitting. The 22" wide pant legs were almost always cuffed. Exclusive silk embroidered emblems might be offered near the right pocket.

The pants were made of all wool, wool and cotton blends, or unspecified fabric content, in

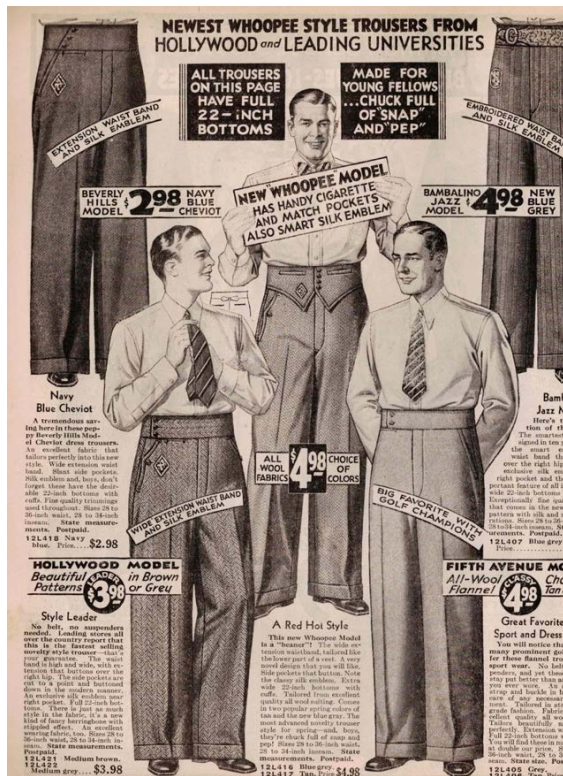

plain weaves, stripes, tweed or herringbone designs. Colors were grey, tan, medium brown, navy blue, and blue grey.

MODEL A ERA FASHION AND STYLE

Sometimes very unusual or colorful pants weren't even identified with the words Whoopee Style. Take a look at the two pair in the ad pictured at right in M.W. Savage Co. Spring & Summer 1931. Very similar trousers (but with 19" wide cuffs) also appeared in 1928's National Bella Hess Co.'s Summer Sale catalog. "Collegiate cut," "Fancy," "Snappy," and "Swagger" are words used to enhance the product descriptions.

Similar pants offered in sizes 6-16 years, and 27"-32" waists, may have had elastic waistbands or elastic waistbands in the back with a plain front. Many listings for young men's or boy's styles such as these models state, "Just like big brother's!" but not, "Just like Dad's!" Hmmm, I wonder why?

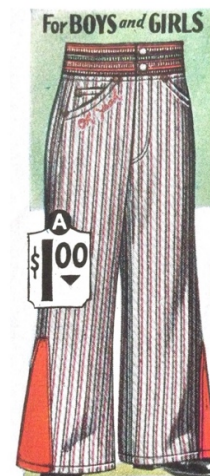

"Whoopee" pants for boys or girls in blue denim with red stitching, or in combinations of red and blue fabric were numerous. There were also examples that were a bit more subdued, but colorful compared to solid fabric with matching color stitching. Overalls and playsuits, stressed durability and were offered in children's sizes. The overalls and denim pants in the ad at far left, came in sizes for boys and girls up to age sixteen years.

All three of the examples above are from M.W. Savage Co. Spring & Summer 1931. Why are so many of my examples from this particular catalog? This catalog just happened to have illustrations in color or with arrangements that copied easily.

MODEL A ERA FASHION AND STYLE

Other Whoopee Clothing

We've looked at "Whoopee" pants for young men and playsuits for children but were there any other types of clothing or age groups targeted for Whoopee advertising? Yes, actually, there are a couple more examples.



This unexpected listing from the Montgomery Ward & Co. Fall & Winter 1929-30 catalog reads, "First seen at the smart resorts – and now gaining popularity everywhere. Wear them **over** [emphasis mine] your regular stockings for an extra touch of smartness." These colorful anklets are offered in women's sizes 7 – 10, and are more colorful than the other women's hose and socks in this catalog.



The shoes at left earned their moniker of Whoopee Booties. Offered in patent leather, in red with black trim or black with red trim, these would have been very colorful additions to a women's outfit, and at \$4.98 a pair, were priced \$1 – \$2 higher than most women's leather shoes.

The men's shoe ad to the right uses Whoopee! with great affect. From March, 1929, it describes the shoe as having a "Whoopee heal plate, toe tappers..." and appears to have the word Whoopee printed or etched into the sole, just in case anyone needed clarification. Special thanks to MAFCA Fashion Editor, Sherry Winkinhofer, for these two ads.

Winners and Duds

All of the examples seen above seem to have earned their descriptions as "Whoopee Style" to varying degrees. Below are a couple of duds in my opinion, where the word whoopee is clearly added to get the reader's attention, but the products are plain and without any stylistic flair.

MODEL A ERA FASHION AND STYLE



While this pair of men’s shoes is typical for the time period and seem nice enough, the only new aspect is that they are now offered in navy blue in addition to the usual black or brown. Is this flamboyant enough to earn a Whoopee appellation?

The men’s wool hat to the right first appears to be shapeless and without spark, but imagine it in Royal blue, light green, red or purple! Maybe it has earned its Whoopee title after all, but I wonder just how many were sold or worn in public. Both of these listings are from National Bella Hess Co. Spring & Summer 1930.



Conclusion

I hope you got a kick out of my casual sampling of Model A clothing ads. Interestingly, I didn’t find any ads for women’s dresses, pants or pajamas using the term Whoopee. And definitely not a single ad for any women’s step-ins, bloomers, or any kind of underwear or union suit for women or men. Was “Whoopee Style” a distinctive style in the Model A years? I highly doubt it, but the catch phrase absolutely got my attention!

Sources:

- Montgomery Ward & Co. Chicago, Fall & Winter 1929-30.
- M.W. Savage Co. Minneapolis, Minn. Spring & Summer 1931.
- National Bella Hess Co. Inc. New York City, Annual Summer Sale Catalog, 1928.
- National Bella Hess Co. Inc. New York City, Spring & Summer, 1930.

#####

THE SHADE TREE A'S – THIRTY YEARS AGO



The 1985-2005 *Shade Tree A's Newsletters* are now available on the Shade Tree A's website. They can be accessed via the same "button" as the other *Newsletters*, but they are password protected. The same password used to access the member roster is used to access the *Newsletters*. Thank you Dan Perla for scanning these and posting on the website.

The May 1994 issue of the *Shade Tree A's Newsletter* stated that May would be one of the busiest ever for the Shade Tree A's. Several upcoming events were discussed including the monthly breakfast at Old Hickory House followed by a fuel economy tour to Clark Hill Lake (course determined by Frank Knapp), a three day tour to Charleston, South Carolina and a tour to Redcliffe Plantation. The Authenticity and Troubleshooting column discussed the Winfield vibration dampener to reduce engine vibrations. The "Rest of the Story" for the Richmond Hill tour was also included in pictures.

HENRY "A" SEZ...



THE EASY WAY TO ADD WATER TO THAT "HARD TO GET AT" BATTERY IN YOUR MODEL "A," IS WITH AN ORDINARY TURKEY BASTER.



Monroe Wade is all smiles after enduring giant sundrops all the way to Richmond Hill.

Bob Jones can not believe his eyes!



The LAST group picture.

TECHNICAL TOPICS

Jim's Tech Tips

"Check Your Rear Axle Nuts"

Every time I have a rear wheel off of a Model A, I use the opportunity to check the tightness of the rear axle nut for that wheel. They are supposed to be quite tight, and yet I find many with at least one axle nut that is loose. This is not good. If the hub is able to move on the axle, it will cause excess wear to the end of the axle and can damage it to the point where the axle will need to be replaced.

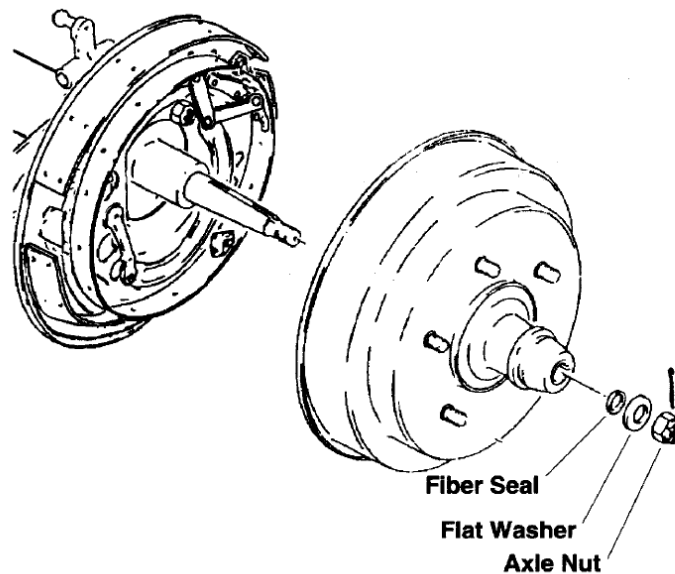

To check it, first remove the cotter key. With the transmission in 1st or Reverse gear, and the opposite rear tire on the ground, you can apply a wrench to the axle nut and confirm it is tight.

Ford did not publish torque values for nuts and bolts; he counted on the experience and "feel" of expert mechanics to know how tight to make things. Les Andrews has a value of 125 ft-lbs. in his book for this nut, and I feel that is a good target to shoot for. Watch the position of the cotter pin hole relative to the slots in the axle nut. If the pin will not line up on the nut, keep tightening the nut until the cotter pin goes in. Bend the ears over. I use a new cotter pin every time.

This simple maintenance step will help you avoid bigger problems down the road.

Until next time, *Have a Model A Day!*

Jim

Member Advertisements

Deadline for submittal – 20th of the month – Send submittals to newsletter@ShadeTreeAs.org

FOR SALE:

Original Model 'A' flywheel housing, no cracks, bead-blasted, painted and ready to install. \$135.
Pick it up at my home in Evans, GA. Bring cash. Don Turley 706-589-0738

MOVING SALE: Many of you may know Ralph and Madge Roub of the Old 96 District Model A Club. They will soon be moving back to Ohio to be with family. They will have items for sale daily, except for Sundays. Also no sales on Friday May 3rd. The sale will resume on Saturday May 4th. There are Model A parts, yard and home items to be sold. Give them a call at 864-992-3230 if you're looking for something in particular.

Paid Advertisements

SHADE TREE A'S NEWSLETTER SPONSORS

Our thanks to the following sponsors! Their generosity supports this Newsletter and the Shade Tree A's! Please remember these folks when you need a service they offer. And please, tell them you appreciate their support of our club!

Matt Barrett
706-799-3699



*Vintage 1930 Model A Ford
Available For Special Occasions*

BARRETT SUPPLY CO. INC.
Distributor of Wholesale Plumbing
Irrigation, Pump Supplies, Industrial Plastics
Since 1922

GEORGE FISHER

P.O. Box 1423
Augusta, GA 30903
2501 Mike Padgett Hwy.
Augusta, GA 30906
georgef@barrett.supply

Bus: (706) 771-9800
Toll Free: 1-800-364-2124
Cell: (706) 513-9655

Bentley's
Antique Auto Service, Inc.

We are a Full Service Shop, specializing in Model A Fords
We offer Award-Winning Paint and Bodywork
Expert Service and a Complete Machine Shop

Enjoy the Drive...

678-407-1947



**Bert's Model "A"
Ford Center**

2767 S. Tejon, Englewood, CO 80110
ph# 303-293-3673 or 800-321-1931
email address - parts@modelastore.com
www.modelastore.com

We buy and sell original and reproduction Model A Ford parts!

Big Dog Stump & Tree



No BONES about it,
We are the BEST!
3 I.S.A. Certified
Arborist on staff
(706) 447-8787

bigdogdisposal@bellsouth.net
P.O. Box 211063 • Martinez, GA 30917

BRATTON'S
ANTIQUE AUTO PARTS



800-255-1929 Phone
www.brattons.com
 800-774-1930 Fax
 1606 Back Acre Circle
 Mount Airy, MD 21771

Your source for Quality Model A Ford Parts since 1976



cicis
pizza™

BENJAMIN HUTTO
 Operator/Owner

bhutto@cicis.com
 4025 Wheeler Rd | Augusta, GA 30907
 o 706.364.6659
 c 803.665.6909

1003 ALEXANDER DRIVE
 AUGUSTA, GA 30909

P.O. BOX 212072
 MARTINEZ, GA 30917



D'Antignac & Merritt Heating & Air, Inc.

Turn To The Experts.

(706) 667-0196

Doug Wilson



Since 1980
 Augusta, Georgia

SALES & SUPPLIES
www.furnituredoctor.net

Walter Smith

Office: 706-798-5951
 Fax: 706-798-7658

3323 Peach Orchard Road
 Augusta, GA 30906
supplies@furnituredoctor.net

Providing Services for Estate Liquidations

Complete Line of Refinishing Supplies for Professional and Do-It-Yourselfers

BUY • SELL • TRADE



CLICKAROO.COM

GUBEN'S



GARAGE

Eric Shogren
 (803) 215-3276
ericshogren@gforcecable.com

POWDERCOATING
 Professional Powdercoating Service

JRPW Racing Inc.

200 Rose Street
 Martinez, GA 30907
info@jrpwrcing.net

Jimmy Rivers
 706-863-1206

Mike's "A" Ford-able Parts



Mike Butcher

124 Model A Drive, Maysville, GA 30558
 email: mike@mikes-afordable.com - www.mikes-afordable.com
 Fax: 706 652 2492 - Phone: 706 652 3866
 1 888 TRY MIKE (879 6453)



Specialising in 1928 - 1931 Model A Ford Parts

ANDREW MORSE
 Buy • Sell • Trade
 Paint & Body
 706-834-2342
 Antique Classic & Street Rods

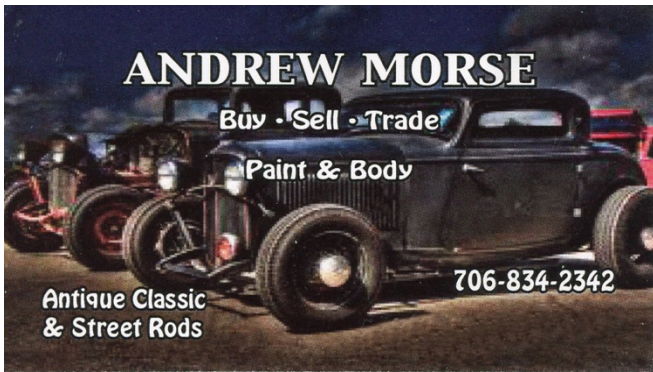

"ONE MILE AHEAD"
Smith and Jones
ANTIQUÉ AUTO PARTS
 SPECIALIZING IN MODEL A AND MODEL T PARTS
 60 Wisconsin St, W Columbia, SC 29170
 Quality Parts • Same Day Shipping
 • Established 1972 •
 Order Desk 1-800-422-1928
 1-803-822-4141 • Fax 1-803-822-8477
 All Major Credit Cards Accepted



Davin E. Smith
 Orders: www.snjparts.com
 Email: snjparts@gmail.com

The World's Largest Selection of 1909-31 Ford Parts

Snyder's
ANTIQUÉ AUTO PARTS
 12925 Woodworth Rd. • New Springfield, OH 44443
 Toll Free Ordering (888) 262-5712
 or FAX (888) 262-5713
 Order On-Line @ www.snydersantiqueauto.com



FREE Fully Illustrated CATALOG
 \$10.00 outside the U.S., Canada, & Mexico

Joseph E. Spires
 ATTORNEY-AT-LAW

Ward & Spires, LLC
 445 Walker Street
 Augusta, Georgia 30901

Phone (706) 724-2640
 Facsimile (706) 724-2642
 E-mail: Wardspires@aol.com

State Farm

Keith Perret, Agent

2350 Washington Road
 Augusta, GA 30904-3162
 Cell 225-326-4014
 Bus 706-925-LIFE (5433) Fax 706-434-0438
keith@kpinthehouse.com
kpinthehouse.com

The greatest compliment you can give is a referral.



Stuckey's ^{SINCE 1937}

Founded in 1937 by W.S. Stuckey, Sr.
 with a Model A Ford & a \$35 Loan

Come Visit Us! • 705 S. Main Street • Wrens, GA
stuckeys.com

Super Shine CAR WASH

 [mrcarwash](https://www.instagram.com/mrcarwash)
mrcarwashga.com
supershinecarcare@gmail.com

Broderick "Brodie" Godbee
 LICENSED AND INSURED
 Hand Wash, Wax and Custom Detailing

678-325-8448
 134 Davis Rd.
 Martinez, GA 30907

4750 Washington Rd.
 Evans, GA 30809

JAMIE & LANIER DUKES
 Owners

Wife Saver RESTAURANTS 

CATERING AVAILABLE

3316 Washington Road
 Martinez, Georgia 30907
 706-860-2605
lanierdukes123@gmail.com

